

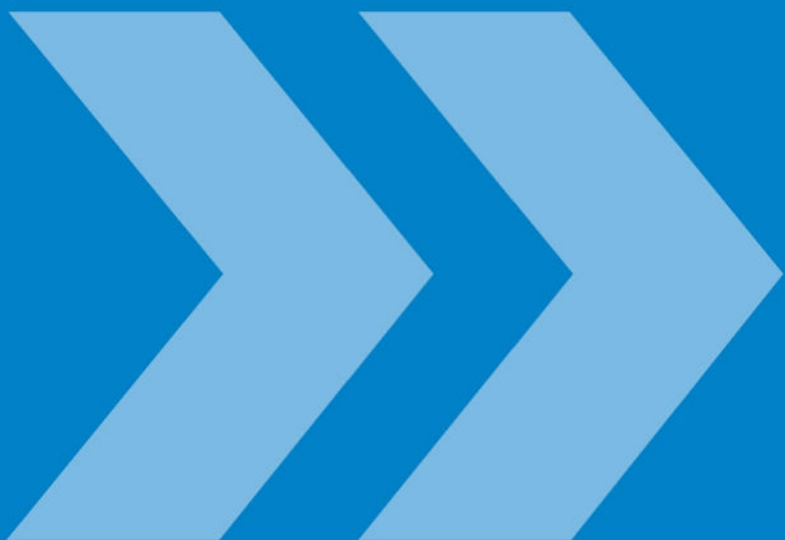

**TX5634 to TX5639**

Vibration Sensor



**TROLEX**«

# User Manual



## TX5634 to TX5639 Vibration Sensor

### Contents

<b>1. Product Overview</b>	<b>4</b>	3.3 Installation	11
1.1 Operating Features	4	3.4 Connections	12
1.2 Application	5	3.4.1 Electrical Connections	
1.3 Product Options	5	to Lead	13
1.3.1 Acceleration Mode	5	3.4.2 Electrical Connections to 4 Pin	
1.3.2 Velocity Mode	6	M12 Type Connector	14
1.4 Dimensions	6	<b>4. Maintenance</b>	<b>15</b>
1.5 Technical Information	7	4.1 Introduction	15
1.6 Electrical Details	7	4.1.1 Vibration Sensor - Check	15
<b>2. Certification</b>	<b>8</b>	4.1.2 Vibration Sensor - Calibrate	15
2.1 Europe (ATEX)	8	<b>5 Disposal</b>	<b>16</b>
2.2 International (IECEX)	8	<b>6 Maintenance Records</b>	<b>16</b>
2.3 Russia (GOST-R)	9	6.1 Maintenance and	
2.4 South Africa (MASC)	9	Calibration Log	17
<b>3. Installation</b>	<b>10</b>	<b>Disclaimers</b>	<b>18</b>
3.1 Safety Precautions	10	<b>Trademarks</b>	<b>18</b>
3.2 Tools and Test		<b>Contact Details</b>	<b>18</b>
Equipment Required	10	<b>Document History</b>	<b>18</b>

## 1. Product Overview



**TX5634**  
**to**  
**TX5639**

Conditioned 4 to 20 mA output signal  
Choice of two output signal formats, Acceleration or Velocity  
Choice of mounting options

### 1.1 Operating Features

- Compact and robust for use in heavy duty industrial applications
- Corrosion resistant stainless steel housing
- Choice of mounting options
- Standard 4 to 20 mA output signal
- Certified for use in mining or hazardous industrial areas
- No moving parts
- Available in a range of measuring ranges

## 1.2 Application

Vibrating condition monitoring on motors, pumps, gearboxes, compressors, generators, rotating machinery and vibrating structures. Detection of low frequency structural oscillations or excessive vibration at shaft rotational frequencies and high frequencies, as generated by deteriorating bearings and by resonant structures.

The sensor can also be used in the opposite mode, where it detects the absence of vibration on a machine that should normally be vibrating, thus indicating the failure of a drive motor, a severed coupling or a power failure. Vibrating screens and material conveyancing ducts or processing machines are typical examples.

It is possible to combine both modes of monitoring simultaneously by using the Trolex TX9042/4 Programmable Vibration Sensor Controller with frequency input conditioning modules.

A range of instrumentation and monitoring modules is available from Trolex to which vibration sensors can be directly connected to provide a flexible choice of display and control functions.

## 1.3 Product Options

### 1.3.1 Acceleration Mode

#### **Vibration Sensor with 4 to 20 mA Output - Acceleration Mode**

Industrial Hazardous  
Areas Ex ia - Group II  
TX5634

General Purpose  
TX5635

Underground Mining  
Ex ia - Group I  
TX5636

Please specify the range required:

- 0 to 2 g
- 0 to 5 g
- 0 to 10 g
- 0 to 20 g
- 0 to 50 g
- 0 to 100 g

## 1.3.2 Velocity Mode

### Vibration Sensor with 4 to 20 mA Output - Velocity Mode

Industrial Hazardous  
Areas Ex ia - Group II

TX5637

General Purpose

TX5638

Underground Mining  
Ex ia - Group I

TX5639

Please specify the range required:

- 0 to 20 mm/s
- 0 to 25 mm/s
- 0 to 50 mm/s
- 0 to 100 mm/s

## 1.4 Dimensions

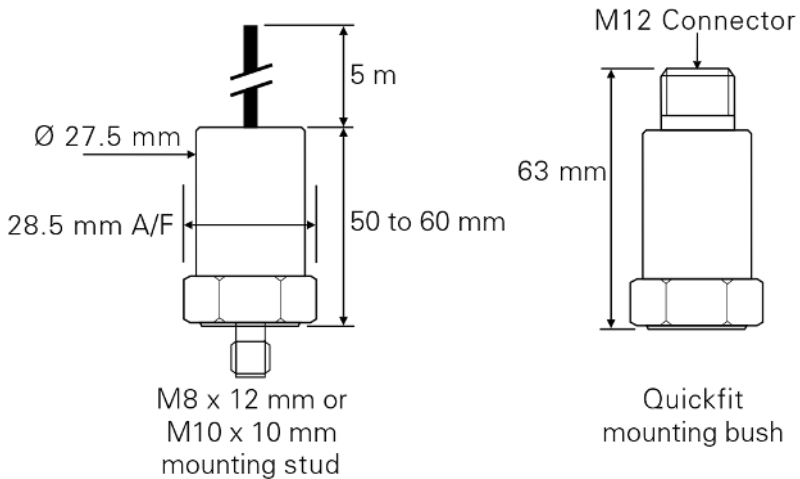

## 1.5 Technical Information

Description	TX5634, TX5635 and TX5636	TX5637, TX5638 and TX5639
Measurement mode	Overall average vibration <b>acceleration</b>	Overall average vibration <b>velocity</b>
Output data	dc output proportional to average high frequency vibration	dc output proportional to average low frequency vibration
Measuring range	2, 5, 10, 20, 50 and 100 g RMS	20, 25, 50 and 100 mm/s RMS
Sensing principle	Piezo-electric	
Frequency response	10 Hz to 5 kHz	10 Hz to 1 kHz
Mounted resonance	10 kHz	5 kHz
Housing material	Stainless steel	
Operating temperature	-40°C to +60°C	
Protection classification	IP67	
Mounting	M8 x 12 mm or M10 x 10 mm mounting stud or Quickfit bush	
Electrical connections	2 core screened and armoured cable or 4 pin M12 type connector	

## 1.6 Electrical Details

Description	General Purpose	Underground Mining Ex ia Group I	Industrial Hazardous Areas Ex ia - Group II
Output signal	4 to 20 mA	4 to 20 mA	4 to 20 mA
Supply voltage	10 to 32 V dc	12 V dc	10 to 32 V dc
Terminal parameters	n/a	Ui - 16.5 V	Ui - 28 V Ii - 115 mA Pi - 0.65 W
Supply current	2 wire line powered		
Maximum load impedance	600 ohms	250 ohms	600 ohms

## 2. Certification

### 2.1 Europe (ATEX)

Ex Certificate number: Baseefa 08ATEX0090X

Ex Certification codes: I M1 Ex ia I Ma (-40°C ≤ Ta ≤ +60°C)

II 1GD Ex ia IIC T6 Ga (-40°C ≤ Ta ≤ +60°C)

II 1GD Ex ia IIIC IP65 T80°C Da (-40°C ≤ Ta ≤ +60°C)



#### **Specific Conditions of Use (Group II Dust) - applies to TX5634 and TX5637 only**

The free end of the cable on the integral cable version of the apparatus must be terminated in an appropriately certified dust proof enclosure.

#### **General Conditions of Use**

Prior to installation, it is essential that user refers to the above certificate to ensure that the termination and cable parameters are fully complied with and are compatible with the application. Copies of certificates are available from Trolex.

ATEX Directive (94/9/EC)

EMC Directive (2004/108/EC)



### 2.2 International (IECEx)

Ex Certificate number: IECEx BAS 08.0035X

Ex Certification codes: Ex ia I Ma (-40°C ≤ Ta ≤ +60°C)

Ex ia IIC T6 Ga (-40°C ≤ Ta ≤ +60°C)

Ex ia IIIC IP65 T80°C Da (-40°C ≤ Ta ≤ +60°C)



#### **Conditions of Certification (Group II Dust)**

The free end of the cable on the integral cable version of the apparatus must be terminated in an appropriately certified dust proof enclosure.

#### **General Conditions of Use**

Prior to installation, it is essential that user refers to the above certificate to ensure that the termination and cable parameters are fully complied with and are compatible with the application. Copies of certificates are available from Trolex.



## 2.3 Eurasian Customs Union



Ex certificate number: TC RU C-GB.AA87B.00632/21  
Ex Certification code: PO Ex ia I Ma X (-40°C ≤ Ta ≤ +60°C)  
0Ex ia IIC T6 Ga X (-40°C ≤ Ta ≤ +60°C)

### Conditions of Use

Prior to installation, it is essential that user refers to the above certificate for any specific conditions of use. The user must ensure that the termination and cable parameters are fully complied with and are compatible with the application. Copies of certificates are available from Trolex.

### Specific Conditions of Use (Group II Dust)

The free end of the cable on the integral cable version of the apparatus must be terminated in an appropriately certified dust proof enclosure.

### General Conditions of Use

Prior to installation, it is essential that user refers to the above certificate to ensure that the termination and cable parameters are fully complied with and are compatible with the application. Copies of certificates are available from Trolex.

## 3. Installation

### 3.1 Safety Precautions

#### **Hazardous areas**

Do not disassemble the sensor whilst in a hazardous area or use a sensor that has a damaged housing in the hazardous area.

Protect the Vibration Sensor from excessive shock during handling and installation as this may cause permanent damage to the internal piezo crystal assembly.

If possible, mount the sensor in a position where it is protected from direct impact and blows.

### 3.2. Tools and Test Equipment Required

No special tools are needed.

## 3.3 Installation

### Checkpoint

The best performance will be obtained from the Vibration Sensor by careful consideration of the mounting position.

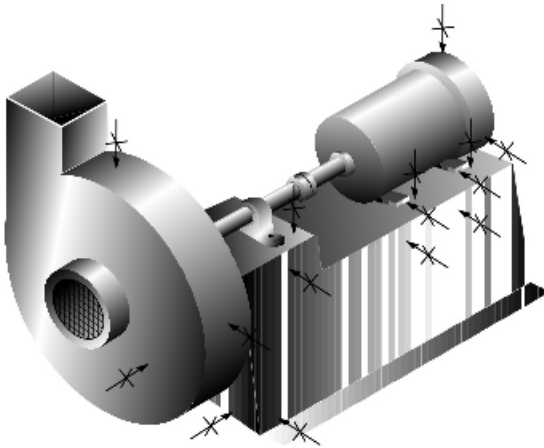

TYPICAL MACHINE WITH FABRICATED BASE

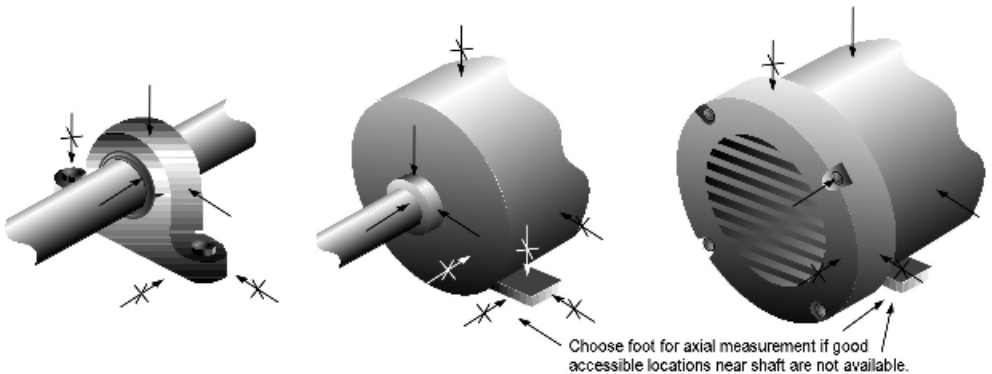

PILLOW BLOCK BEARING

MOTOR DRIVE END

MOTOR FAN GUARD END

1. Maximum output will be generated when the vibration is acting along the centre axis of the sensor. This is particularly important when monitoring bearings and ventilation fans.
2. The sensor is equally effective at detecting vibration in housings and casings. It is important to identify points of vibration where the maximum output signal can be obtained.
3. It is important to prepare an accurate mounting point for the Vibration Sensor and if possible, choose a relatively flat area where a spot face of about 25 mm can be created.

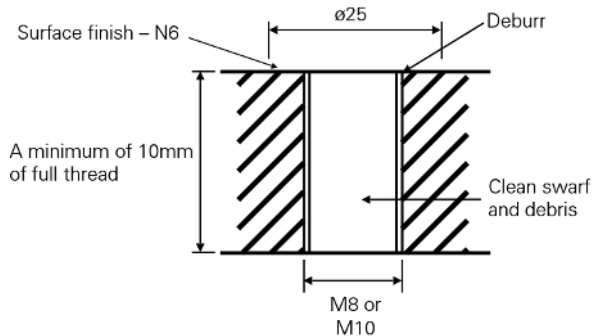

4. Apply a small amount of suitable thread lock to the mounting bush to ensure a good vibration coupling.
5. Tighten the Vibration Sensor to 8 Nm.
6. Movement of the cable itself can influence the output signal. Clip the cable as close as possible to the Vibration Sensor to restrain it.

## 3.4 Connections

In order to avoid electrical pickup through the case of the sensor from the machine being monitored, the machine should be properly earthed in compliance with local regulations.

It is recommended that the sensor cable is looped and then tied with a cable tie to the main body in order to avoid excessive wear.

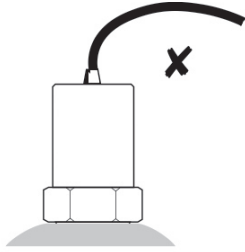

Loose cable causes vibration and wear

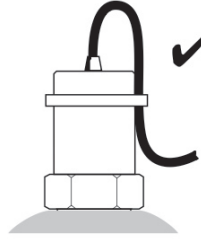

Secure Cable

## 3.4.1 Electrical Connections to Lead

### Checkpoint

If a good earth is not possible, the sensor and the cable overbraid should be electrically isolated from the machine. The screen of the cable should be connected to earth at the monitoring equipment, it should not be earthed at the motor. The cable overbraid should be left unconnected.

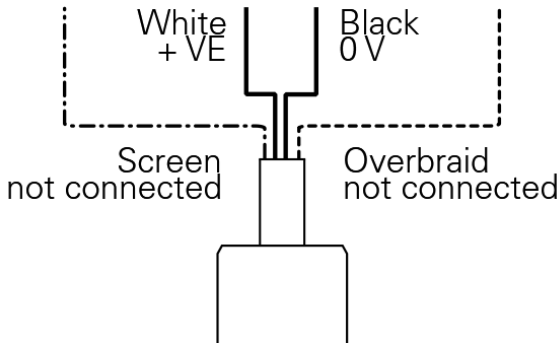

## 3.4.2 Electrical Connections to 4 Pin M12 Type Connector

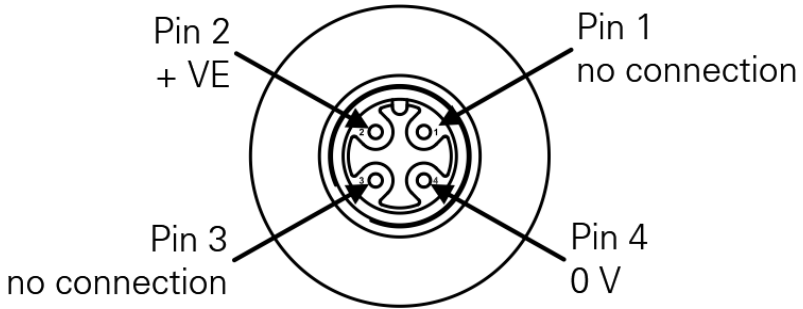

### Checkpoint

The minimum cross sectional area of the wiring used between the circuit to the transition PCB is 0.085 mm<sup>2</sup>.

The electrical circuit in the hazardous area (black and white wire) must be capable of withstanding an ac test voltage of 500 V RMS to (inner cable screen or enclosure body and external screen) for 1 minute.

## 4. Maintenance

### 4.1 Introduction

To keep your Vibration Sensor in the best possible condition and minimise downtime, Trolex strongly recommends that you carry out regular planned preventative maintenance and keep records of the maintenance carried out. The planned preventative maintenance for the Vibration Sensor consists of a number of tasks to be carried out at regular intervals. These tasks are listed in the maintenance schedule below:

Equipment Name	Task Type	Task Number	Interval
Vibration Sensor	Check	4.1.1	3 months
Vibration Sensor	Calibrate	4.1.2	12 months

#### 4.1.1 Vibration Sensor - Check

1. Check the exterior of the vibration sensor for cracks, penetration and any other signs of damage.
2. Check that the wiring is secure and free from damage.
3. Check that the vibration sensor is securely mounted.
4. If any part of the vibration sensor shows any signs of damage, deformation or missing parts, contact your local Trolex service agent or **service@trolex.com** for advice on repair or replacement.
5. After the completion of all maintenance, update the maintenance records.

#### 4.1.2 Vibration Sensor - Calibrate

1. Under normal circumstances, the calibration of the vibration sensor will not change significantly.
2. Check the accuracy by comparing the display reading with a reference value of frequency.

OR

2. Alternatively the vibration sensor can be removed and returned to your local Trolex service agent, for checking and calibration across the full operating spectrum. Contact **service@trolex.com** for further information.
3. After the completion of all maintenance, update the maintenance records.

## 5. Disposal

Part of the ethos of Trolex is sustainable design. The vibration sensor contains materials that can be recovered, recycled and reused. At the end of its useful life ensure that the vibration sensor is recycled in accordance with local laws and bylaws for the geographic area where it is located. The end of its useful life is to be determined by the owner/operator of the equipment and not Trolex. Ensure that the vibration sensor is recycled by licenced waste contractors with the appropriate licences for handling metallic waste in the geographic area where the vibration sensor is located.

### Checkpoint

Consult your local Trolex service agent or the Trolex Product Support Department if you require assistance with disposal:

**service@trolex.com**

## 6. Maintenance Records

Implement a planned preventative maintenance process and keep good maintenance records.

Consult your local Trolex service agent or the Trolex Product Support Department: **service@trolex.com** for help in implementing a planned preventative maintenance process.

The 'Maintenance Log' gives an example of a typical maintenance record system.



6.1 Maintenance and Calibration Log

Order Reference: TX	
Serial Number:	Date Purchased:
Location:	

Date	Scheduled Check	Fault	Recalibrate	Return to Trolex	Comments

## Disclaimers

The information provided in this document contains general descriptions and technical characteristics of the performance of the product. It is not intended as a substitute for and is not to be used for determining suitability or reliability of this product for specific user applications. It is the duty of any user or installer to perform the appropriate and complete risk analysis, evaluation and testing of the products with respect to the relevant specific application or use. Trolex shall not be responsible or liable for misuse of the information contained herein. If you have any suggestions for improvements or amendments, or find errors in this publication, please notify us at [marketing@trolex.com](mailto:marketing@trolex.com).

No part of this document may be reproduced in any form or by any means, electronic or mechanical, including photocopying, without express written permission of Trolex.

All pertinent state, regional, and local safety regulations must be observed when installing and using this product. For reasons of safety and to help ensure compliance with documented system data, only Trolex or its affiliates should perform repairs to components.

When devices are used for applications with technical safety requirements, the relevant instructions must be followed.

## Trademarks

© 2021 Trolex® Limited.

Trolex is a registered trademark of Trolex Limited. The use of all trademarks in this document is acknowledged.

## Document History

Issue 05 8 April 2015 Fifth publication of this document

Issue 06 26th March 2021 Updates to Certification Section ECR: 5230

## Contact Details

Trolex Ltd, Newby Road, Hazel Grove, Stockport, Cheshire, SK7 5DY, UK  
+44 (0) 161 483 1435 [sales@trolex.com](mailto:sales@trolex.com)



**TROLEX**«

**Trolex Ltd.** Newby Road, Hazel Grove, Stockport, Cheshire SK7 5DY, UK  
**t:** +44 (0)161 483 1435 **e:** sales@trolex.com [www.trolex.com](http://www.trolex.com)