



**A TEX  
M1  
GROUP I & II  
INTRINSICALLY  
SAFE**

**PETROCHEMICAL  
PROCESSING**

**MINING &  
TUNNELLING**

**OFFSHORE PLATFORMS**

**MANUFACTURING &  
PROCESS PLANTS**

**STORAGE AREAS &  
WAREHOUSING**

**WATER MANAGEMENT  
& SEWAGE  
TREATMENT**

**POWER  
GENERATION**

**GAS STORAGE &  
DISTRIBUTION**

**MARINE & SHIPPING  
APPLICATIONS**

**TELECOMS**



# FLAMMABLE GAS SENSOR/TRANSMITTER

## INSTALLATION & OPERATING DATA

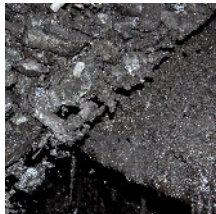

### contents...

	page
<b>1</b> PRINCIPAL OPERATING FEATURES	2
<b>2</b> APPLICATION	3
<b>3</b> DIMENSIONS	4
<b>4</b> TECHNICAL DETAILS	4
<b>5</b> INSTALLATION	6
<b>6</b> CONNECTIONS	11
<b>7</b> CONTROLS AND INDICATORS	14
<b>8</b> CALIBRATION	15
<b>9</b> MAINTENANCE	20
<b>10</b> APPROVALS AND CERTIFICATION	23
<b>11</b> FUNCTIONAL SAFETY	25

**INSTALLATION & OPERATING DATA**

**1 PRINCIPAL OPERATING FEATURES**



Stationary gas sensors for the detection of a wide range of flammable gases.

Suitable for use in SIL 1 and SIL 2 applications, in accordance with any conditions or restrictions

Poison resistant CATALYTIC COMBUSTION sensors.

Pre-calibrated plug-in gas sensing module with a standardised output signal for convenient replacement and servicing.

Calibration available for a wide range of flammable gases.



LCD readout of gas concentration with OVERRANGE indication.



Convenient push button calibration of ZERO and SPAN.

Signal fix during calibration to prevent false alarms.

Output signal versions:- 4 to 20 mA 0.4 to 2 V 5 to 15 Hz.



Stainless steel reinforced polycarbonate housing.

Intrinsically safe for use in Group I and Group II hazardous areas.



Special versions with weatherproof plug and socket connections in place of cable glands.



Optional format with remote mounted gas sensing module in robust metal housing.

**Ex**  
**A T E X**  
**M1**  
**GROUP I&II**  
**INTRINSICALLY**  
**SAFE**

**INSTALLATION & OPERATING DATA**

**2 APPLICATION**



Fixed gas monitoring for point-source hazards and perimeter protection in arduous duty and exposed locations. Safety protection for toxic gas risk occurring in hazardous areas and general industrial applications.

- Petrochemical processing.
- Mining and tunnelling.
- Offshore platforms.
- Manufacturing and process plants.
- Storage areas and warehousing.
- Water management and sewage treatment.
- Power generation.
- Gas storage and distribution.
- Marine and shipping applications.
- Telecommunications.

A choice of output signals for direct interfacing with most standard industrial monitoring systems.

A range of primary instrumentation and monitoring modules is available from Trolex to which the sensors can be directly connected to provide a flexible choice of display and control functions.

**Ex**  
**A T E X**  
**M 1**  
**GROUP I & II**  
**INTRINSICALLY**  
**SAFE**



**TRIP AMPLIFIER**  
 for use with  
 analogue output sensors.



**CONFIGURABLE SENSOR CONTROLLER**  
 for monitoring up to  
 8 analogue output sensors.



**COMMANDER DISTRIBUTED I/O SYSTEM**  
 for large scale general plant monitoring systems  
 and the mining and tunnelling industries.

**INSTALLATION & OPERATING DATA**



**3 DIMENSIONS**

**3.1 TX6383 Flammable Gas Sensor/Transmitter**

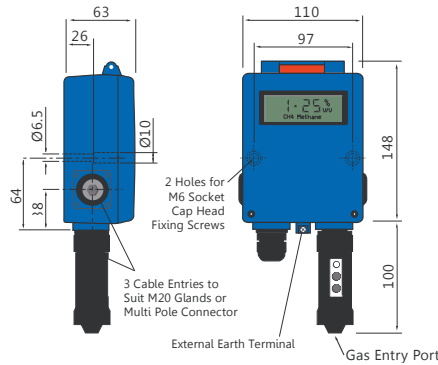

**3.2 TX6383.84 Flammable Gas Sensor/Transmitter with Remote Gas Sensing Module**

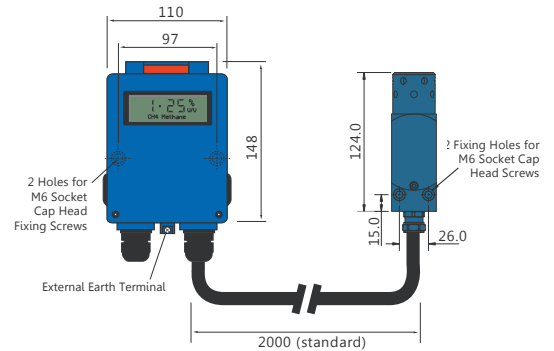

ALL DIMENSIONS IN MM

**4 TECHNICAL DETAILS**

**4.1 Specification**

Operating Temp. Limits:	-10 to +40°C (Ambient temp. range for explosion protection: -20 to + 40°C)
Storage Temperature:	-25 to +60°C
Ambient Pressure Limits:	1000 mbar ± 200 mbar absolute
Humidity:	95% RH non-condensing
Protection Classification:	Dust and waterproof to IP66. Gas inlet port to IP54
Housing Material:	Reinforced polymer - proof against electrostatic discharge
Nett Weight:	450 g
Cable Entries:	M20 x 1.5
Electrical Connections:	4 mm Barrier/clamp terminals
Information Display:	Graphic LCD
Impact Limits:	20 joules (Housing)

**GAS SENSING MODULE**

Plug-in gas sensing module with signal conditioning. Precalibrated and standardised output signal.

Measuring Range:	0 to 5% v/v CH <sub>4</sub> . Calibrated for Methane Alternative sensing ranges available to specification
Linearity:	±1% 0 to 60% FULL SCALE ±5% from 60% up to 100% FULL SCALE
Maximum Drift @ 25°C:	±0.25% v/v per month
Response Time t(90):	<30 seconds response time is tested by flowing test gas using the calibration kit referred to in section 9 maintenance
Sensing Element Life:	>5 years in clean atmosphere
Warm Up Time:	<5 mins in air or 1% v/v CH <sub>4</sub> .
Stabilisation Time:	>15 minutes
Calibration:	Digitally controlled ZERO and SPAN. Pushbutton setting
Signal Fix:	The transmitted output signal of the sensor is FIXED at 00.0 during calibration to prevent false alarms from being initiated
Overrange:	If the measured gas concentration exceeds the calibration range of the sensor: The STATUS indicator will flash The display value will be CLAMPED The transmitted output signal will be CLAMPED
Pellistor Protection:	The supply to the gas sensing element will be switched off to prevent oxidisation damage occurring if the gas concentration exceeds safe limits. The sensor will attempt to switch back on at 5 minute intervals until the gas concentration has reduced to a safe level





**INSTALLATION & OPERATING DATA**



**4 TECHNICAL DETAILS continued**

**4.1 Specification (cont.)**

The table shows the response variation of the gas sensing module on exposure to a range of gases and vapours at the same %LEL concentration. The figures are experimentally derived and expressed relative to the methane signal (=100).

Gas/Vapour:	Relative Sensitivity	Gas/Vapour	Relative Sensitivity
Methane	100	Carbon Monoxide	130
Propane	70	Hydrogen	120
n-Butane	70	Ammonia	155
n-Pentane	60	Cyclohexane	55
n-Hexane	60	Ethylene	90
Acetylene	85		

**TX6383.01 GROUP I APPLICATIONS (12 V dc)**

Output:	0.4 to 2 V dc	
Min Load	10 k ohms	
Supply	6.5 to 16.5 V dc	
Max Current	80 mA	
Output:	4 to 20 mA	
Max Load @ 12 V	140 ohms	
Supply	6.5 to 16.5 V dc	
Max Current	24 mA	
Output:	5 to 15 Hz	
Max Load	Opto isolated 2 mA max	
Supply	6.5 to 16.5 V dc	
Max Current	80 mA	



**TX6383.02 GROUP II APPLICATIONS (24 V dc)**

<i>When used in conjunction with safety barriers. (Section 6)</i>		<b>Refer to Section 6</b>
Output:	4 to 20 mA	
Max Load @ 24 V	240 ohms	
Supply	Minimum 6.5 V at the sensor supply terminals (3 and 4)	
Max Current	100 mA	

**TX6383.03 GENERAL PURPOSE APPLICATIONS (24 V dc)**

*NOT SUITABLE FOR USE IN CLASSIFIED HAZARDOUS AREAS.*

Output:	4 to 20 mA	
Max Load @ 24 V	240 ohms	
Supply	6.5 to 30 V dc	
Nominal Current	100 mA	

**INSTALLATION & OPERATING DATA**



**5 INSTALLATION**

**5.1 Conformity Check**

(Refer to Test Certificate provided with the sensor).

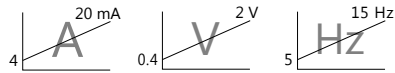

Does the output signal of the sensor concur with the input requirement of the monitoring equipment being used?

**12 V dc    24 V dc**

Is the correct supply voltage available for the sensor?

Is the type of gas and its anticipated maximum level of concentration, within the operating parameters of the sensor?



Is the temperature variation range, at the installation, within the stated temperature range of the sensor?



Is the hazardous area classification correct?

If the hazard is Group II – are the correct safety barriers fitted?

GENERAL PURPOSE

GROUP I

GROUP II

**Ex**  
**ATEX**  
**M1**  
**GROUP I&II**  
**INTRINSICALLY**  
**SAFE**

**STANDARD OPTIONS AVAILABLE**



- TX6383.01    FLAMMABLE GAS SENSOR/ TRANSMITTER    GROUP I**
- TX6383.02    FLAMMABLE GAS SENSOR/ TRANSMITTER    GROUP II**
- TX6383.03    FLAMMABLE GAS SENSOR/ TRANSMITTER    GENERAL PURPOSE**



- TX6383.84.01 FLAMMABLE GAS SENSOR/ TRANSMITTER    GROUP I**  
with Remote Gas Sensing Module
- TX6383.84.02 FLAMMABLE GAS SENSOR/ TRANSMITTER    GROUP II**  
with Remote Gas Sensing Module



- TX6383.84.03 FLAMMABLE GAS SENSOR/ TRANSMITTER    GENERAL PURPOSE**  
with Remote Gas Sensing Module

**TYPE OF GAS**

**Refer to Section 4.2**

OUTPUT SIGNAL	0.4 to 2 V	(11)
	4 to 20 mA	(12)
	5 to 15 Hz output	(13)

**INSTALLATION & OPERATING DATA**

**5 INSTALLATION continued**

**5.2 Location**

It is recommended that user refer to EN/IEC 60079-29-2 for useful information on the selection, installation, use and maintenance of gas detectors for potentially explosive atmospheres.

Each installation needs to be considered in its own right, with reference to safety authorities and in compliance with mandatory local safety regulations. The sensor must be operated in accordance with the Installation and Operating Data to maintain safety, reliability and to preserve Intrinsic Safety integrity where applicable.

It is important that sensors are located in positions determined in consultation with those who have specialised knowledge of the plant or installation and of the principles of gas dispersion. Reference should also be made to those responsible for the engineering layout and topology of the plant as they will be most familiar with the nature of the potential dangers and the most likely sources of gas release.

It is also important to recognise that the characteristics of the gas source can be influenced by many factors; including the relative density or buoyancy of the gas, the pressure at the point of release, the ambient temperature and the ventilation of the site.

Sensor coverage cannot be simply expressed in terms of 'number per unit area'. Sensors need to be sited where they are capable of monitoring those parts of a plant where gas may accumulate or when a source of gas release is expected to occur. This way the earliest possible warning of a gas release can be given to initiate shutdown functions, alarm functions or safe evacuation of the premises.

**5.3 System Integrity**

If a gas monitoring system should fail for any reason, it is important that the system is capable of immediately alerting operational staff to this fact.

The sensor will indicate a system failure or mechanical defect and this information can be utilised to initiate a warning alarm. It is good practice to provide emergency facilities to protect against the loss of the mains power supply.

Standby batteries can be incorporated with automatic changeover facilities, so guaranteeing continued operation of the gas sensing system even in the event of a plant breakdown as a result of a power supply failure.

Certainly, in critical plants, duplication or triplication of sensors is recommended.

The Trolex TX9042 or TX9044 Programmable Sensor Controller can be programmed to operate with sensors in the multiple voting mode.



**5.4 Sensor Management**

A very important part of an efficient gas monitoring system is the training of plant personnel in operation and maintenance of the sensors and the complete monitoring system. Training facilities can be provided by qualified Trolex application engineers.

Once a sensor installation is complete, the sensor locations and types should be formally recorded and a planned test and maintenance procedure instituted.



**INSTALLATION & OPERATING DATA**

**5 INSTALLATION continued**

**5.5 Relative Density**



**CONCENTRATION ZONE**



**CONCENTRATION ZONE**

The relative density or buoyancy of the gas or vapour with respect to air is a very important consideration. This determines its propensity to rise or fall when released into the atmosphere.

Gases or vapours with a buoyancy less than air will tend to rise from the source of release.

Conversely, gases or vapours heavier than air will tend to fall and accumulate in concentrations for long periods of time.

This is a particular problem in pits, trenches, machine rooms, etc. Normal air movements in and around such gas concentrations will have the inevitable effect of producing zones of highly flammable mixtures.

This knowledge of the characteristics of the gas assists when positioning the gas sensor.

The behaviour of the gas accumulation will also be affected by the velocity and location of the gas release and by ambient air movement caused by ventilation systems or draughts.

Pockets of gas can be trapped in trenches or ceiling cavities, all of which adds to the unpredictability of critical gas concentrations.



**ATEX**  
**M1**  
**GROUP I&II**  
**INTRINSICALLY**  
**SAFE**

Hydrogen	LIGHTER THAN AIR
Town Gas	
<b>Methane</b>	
Ammonia	
Acetylene	
Carbon Monoxide	
Ethylene	HEAVIER THAN AIR
Methyl alcohol	
Propane	
Ethanol	
Acetone	
Butane	
Pentane	
Benzene	
Hexane	
Ethylacetate	
Toluene	
Petrol	
O-Xylene	
Octane	



**INSTALLATION & OPERATING DATA**



**ATEX**  
**M1**  
**GROUP I&II**  
**INTRINSICALLY**  
**SAFE**

**5 INSTALLATION continued**

**5.6 Hazardous Areas**

Do not disassemble the sensor whilst in the hazardous area or use a sensor that has a damaged housing in the hazardous area.

**5.7 Evacuation**

If a dangerous level of gas concentration is detected by the instrument, leave the area immediately.

**5.8 Operating Limits of Catalytic Combustion Sensors**

Catalytic combustion gas sensors POSITIVELY detect the presence of any flammable gas. They rely upon the presence of oxygen in the atmosphere and should only be used for gas concentration up to the Lower Explosive Limit (LEL).

After this point, the output becomes non linear and may erroneously indicate that the gas concentration is below the LEL. they should not be used in oxygen enriched or deficient atmospheres.

**5.9 Discrimination**

Catalytic combustion sensors can detect a wide range of flammable gases but they cannot discriminate between individual gases. They will respond to most or all of the flammable components present in the atmosphere without distinguishing between them. (See section 4.1 for relative sensitivities)

**5.10 Contamination**

The response of catalytic combustion gas sensors can be affected by air borne contaminants which will reduce the sensitivity. Substances such as silicones, tetraethyl lead, sulphur compounds and phosphate esters can cause permanent degradation (poisoning). Halogenated carbons may also cause temporary inhibition.

**5.11 Interference**

If the atmosphere to be monitored contains a gas that dilutes or displaces the air, this may reduce the response of catalytic sensors. Similarly, steam laden atmospheres and condensation can reduce the sensitivity.

Air velocity may have a minor effect on the accuracy of the gas sensor.

**INSTALLATION & OPERATING DATA**



**5 INSTALLATION continued**

**5.12 High Concentrations of Flammable Gas**

Exposure of low concentration catalytic combustion sensors to concentrations of flammable gas greater than the LEL can affect the sensitivity and zero stability of catalytic elements and the calibration should be checked after such an exposure.



If the gas concentration does exceed 100% LEL, the supply voltage to the catalytic combustion sensing element will be automatically switched off to prevent damage to the element.

The sensor output signal will be CLAMPED, the display will indicate OVERRANGE and the STATUS indicator will FLASH.

**Refer to Sections  
7, 8.5 & 8.6**

**5.13 Toxicity**

Be aware that most flammable gases and vapours are also toxic at low concentrations of LEL.



**ATEX  
M1  
GROUP I&II  
INTRINSICALLY  
SAFE**

**5.14 New Installations**

Flammable gas sensors based on pellistor technology require regular zero and span check and adjustment operations to ensure that they remain accurate.

**Refer to Section 8**

The pellistor device ages during its lifetime and its baseline and sensitivity characteristics will change. These operations are normally performed three weekly.

The pellistors baseline tends to drift throughout it's lifetime. In the early stages of the lifetime, the baseline tends to move at a relatively fast rate. This movement slows down with age.

The pellistor fitted to the TX6383 will have a baseline change equivalent of upto  $\pm 2.5\%$ LEL (0.11% v/v) in its first month of usage, then a further  $\pm 1.5\%$  LEL (0.066% v/v) in the second month.

For newly installed equipment, end users should consider performing a zero offset adjustment and span check adjustment every two weeks for the first two months. This will ensure that the offset movement is kept below  $\pm 2\%$  LEL (0.088% v/v) during the 'settling in' period.

**INSTALLATION & OPERATING DATA**



**6 CONNECTIONS**

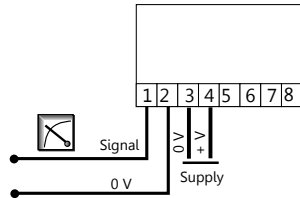

**OUTPUT SIGNAL OPTIONS**

**TX6383 FLAMMABLE GAS SENSOR/ TRANSMITTER**

**6.1 0.4 to 2 V Output Signal**

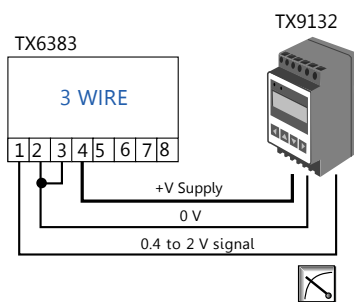

A low impedance two-wire voltage output signal requiring a separate power supply to the sensor. This can be derived from a TX9132 Trip Amplifier or TX9042 Programmable Sensor Controller, when one of those is used as the monitoring instrument.

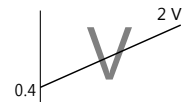

This connection configuration works well up to about 10 m distance between the sensor and the monitoring equipment.

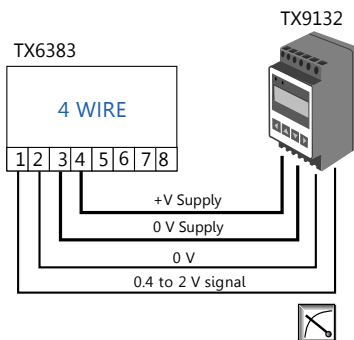

Both the signal and the power supply to the sensor are being carried in the common 0 V conductor so at some point – influenced by the length of the cable and the resistance of the cable cores – the current flowing in the 0 V conductor will impose an unacceptable voltage error onto the signal.

This effect can be reduced on long distance connections by increasing the size of the cable cores, or even better, running a separate 0 V conductor to power the sensor enabling operating distances up to 1000 m.

**APPLICATION**

**GROUP I HAZARDOUS AREAS**

**6.2 4 to 20 mA Output Signal**

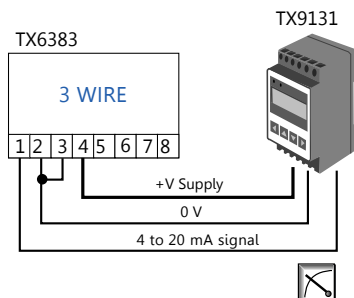

The sensor may be connected the 3 or 4 wire connection mode.

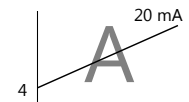

The power supply for the sensor may be sourced from the monitoring equipment (eg. TX9131 Trip Amplifier or a TX9042 Programmable Sensor Controller) or from a separate power supply.

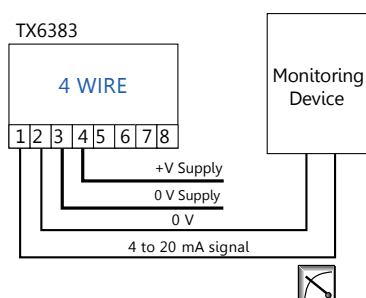

**APPLICATION**

**GROUP I HAZARDOUS AREAS  
 GROUP II HAZARDOUS AREAS  
 GENERAL PURPOSE**



**INSTALLATION & OPERATING DATA**



**6 CONNECTIONS continued**

**6.3 5 to 15 Hz Output Signal**

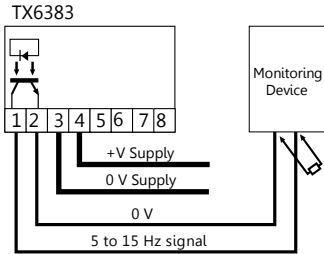

A pull up resistor may be required at the monitoring device.

A square wave, frequency variable output that is proportional to the measured value. The output device is an open collector NPN transistor.



Output:	5 to 15 Hz (zero = 5 Hz) (span = 15 Hz)
Maximum Voltage:	15.4 V
Maximum Current:	2 mA
Minimum Pulse Rise Time:	5 V/ms

**APPLICATION GROUP I HAZARDOUS AREAS**

**6.4 Using Gas Sensors in Hazardous Areas**

**6.4.1 GROUP I HAZARDOUS AREAS (MINING)**

**TX6383.01 FLAMMABLE GAS SENSOR/ TRANSMITTER**



All options of the TX6383.01 sensor (0.4 to 2 V, 4 to 20 mA and 5 to 15 Hz) are certified Intrinsically Safe for use in Group I hazardous areas (Mining) when used with approved equipment eg. TX9131 Trip Amplifier or a TX9042 Programmable Sensor Controller.

THE COMPLETE SYSTEM, BOTH SENSOR AND MONITORING DEVICE, CAN BE MOUNTED IN THE HAZARDOUS AREA.

The interconnecting cable between the sensor and the monitoring device must have steel wire armoured protection or a braided earth screen. The cross sectional area of the conductors must be a minimum of 1 mm<sup>2</sup>.

**6.4.2 GROUP II HAZARDOUS AREAS (24 V dc)**

**TX6383.02 TOXIC GAS SENSOR/ TRANSMITTER**

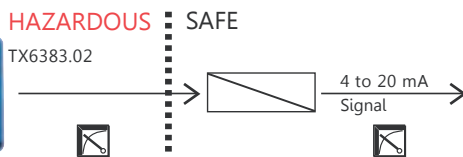

This version of the sensor (4 to 20 mA) is certified Intrinsically Safe for use in industrial hazardous areas, when used in conjunction with safety barriers.

THE SAFETY BARRIERS ARE MOUNTED IN THE SAFE AREA, ONLY THE SENSOR IS MOUNTED IN THE HAZARDOUS AREA.

The system may be used with either zener safety barriers or isolation safety barriers.

**ATEX**  
**M1**  
**GROUP I&II**  
**INTRINSICALLY**  
**SAFE**

**INSTALLATION & OPERATING DATA**



**6 CONNECTIONS continued**

**Group II sensor connections using zener safety barriers.**

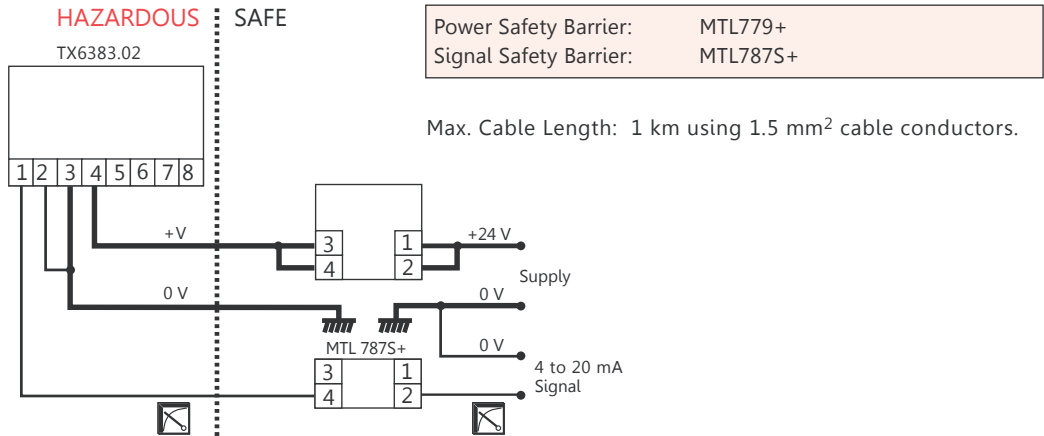

**Group II sensor connections using isolation safety barriers.**

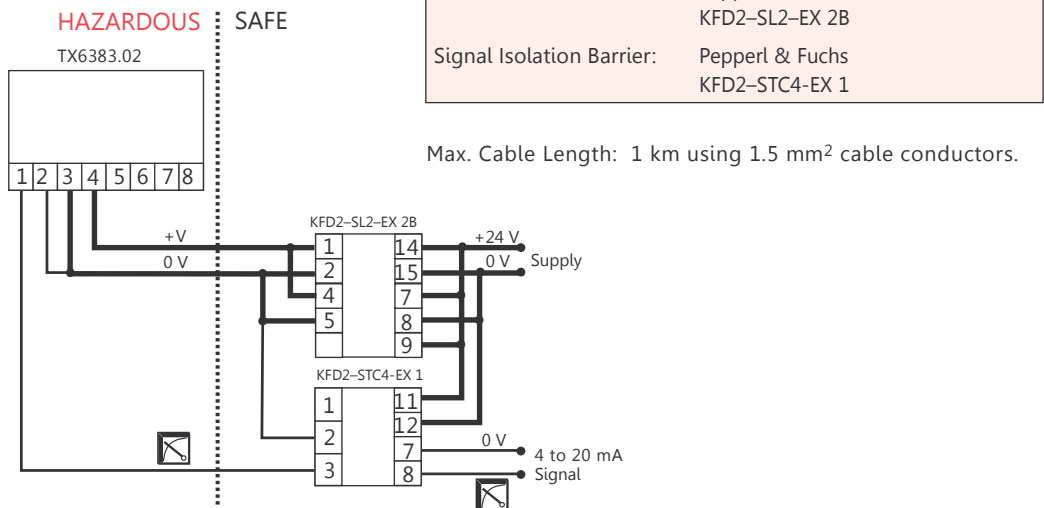

**If you require any help with the use and connection of hazardous area equipment please contact the Trolex Technical Department.**



**INSTALLATION & OPERATING DATA**

**7 CONTROLS AND INDICATORS**

**TX6383 FLAMMABLE GAS SENSOR/**

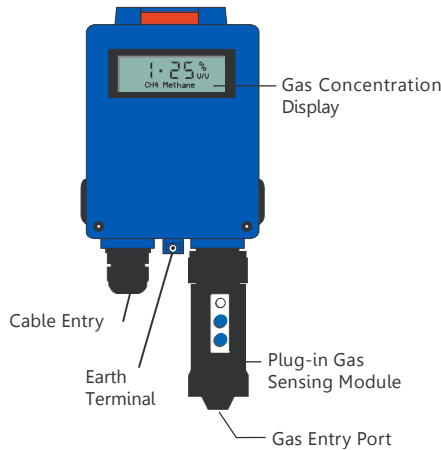

- Calibration STATUS indicator
- SPAN calibrate pushbutton
- ZERO calibrate pushbutton

**TX6383.84 FLAMMABLE GAS SENSOR/ TRANSMITTER REMOTE GAS SENSING MODULE.**

This version uses the same pre-calibrated gas sensing module as the TX6383. The module is fitted into a robust metal housing which can be mounted at a remote location where space is constricted or the operating conditions are extremely harsh.

Connections:	2 m, flexible cable in a flexible armoured conduit (other lengths available to specification. Max 10 m).
Protection Classification:	Dust and waterproof to IP66. Gas inlet port to IP54.
Housing Material:	Brass or Stainless steel.
Maximum Cable Length:	Extendible up to 500 m using 1.5 mm <sup>2</sup> cable conductors. (General Purpose only)

**Ex**  
**ATEX**  
**M1**  
**GROUP I&II**  
**INTRINSICALLY**  
**SAFE**



**CHECK POINT DISCONNECTING THE REMOTE GAS SENSING MODULE**

The connecting cable between the remote gas sensing module and the Transmitter is normally supplied connected at both ends. The cable can be disconnected via a plug and socket connector inside the Transmitter housing for servicing or transportation.

**IMPORTANT!**  
 The Ribbon Cable Assembly must lie flat against the inside rear of the enclosure & must be connected to the feedthrough in the orientation shown.

Double line indicates red marker on ribbon cable.

View showing orientation of ribbon cable. (All other parts removed for clarity).

Secure connector to inside of the enclosure with a double sided adhesive foam pad. (Trim off any excess before fitting).

**INSTALLATION & OPERATING DATA**

**8 CALIBRATION**



The gas sensing module will gradually change its response characteristics, by a small amount, during normal use. The output signal is standardised so the module can be quickly changed when necessary.

Service replacement modules can be supplied by our Product Support Department.

Alternatively the gas sensing module may be re-calibrated when required, using a Trolex TX6520.32 Gas Test Kit equipped with both Air and Test Gas canisters.



Maximum time interval between calibrations should be three weeks.

For newly installed equipment, end users should perform a zero offset adjustment and a span check/adjustment every two weeks for the first two months

**8.1 Prepare to Calibrate**

The sensor should be powered for a minimum of 15 minutes prior to commencing calibration, to allow the sensor to stabilise.

Connect the application tube of the gas test kit to the inlet aperture of the gas sensing module.



The indicator will be GREEN denoting the NORMAL operating condition.



**Ex**  
**A T E X**  
**M 1**  
**GROUP I & II**  
**INTRINSICALLY**  
**SAFE**

**INSTALLATION & OPERATING DATA**

**8 CALIBRATION** continued



**Ex**  
**A T E X**  
**M 1**  
**GROUP I & II**  
**INTRINSICALLY**  
**SAFE**

**8.2 Prepare to Calibrate**



Press **BOTH** pushbuttons on the gas sensing module for about 5 seconds. Then release.



The indicator will be **RED** denoting that the module is now setup ready for:

Calibrate ZERO  
 OR  
 Calibrate

**Refer to Section 8.3**

**Refer to Section 8.4**



When the Gas Sensing Module is setup into the CALIBRATE MODE it will instruct the transmitted output signal of the sensor to be **FIXED** at ZERO SCALE. This will prevent the possibility of false alarm signals being activated in the monitoring equipment during the calibration process.

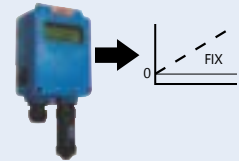

The display will continue to show the measured value of gas concentration during the calibration process.

The gas sensing module will automatically return to the normal measuring mode if the pushbuttons are operated within 60 seconds.

**INSTALLATION & OPERATING DATA**



**8 CALIBRATION** continued



**8.3 Calibrate ZERO**



Apply purge air, at a flow rate of 0.2 to 1 l/min, for 20 seconds to clear all remnants of gas.



Press CALIBRATE ZERO until the indicator is flashing GREEN (about 3 seconds).



The CALIBRATE ZERO will NOT function if any level of gas concentration is detected by the sensing element – The indicator will NOT flash GREEN.



Release and the indicator will briefly show RED to denote ZERO setup.



The Gas Sensing Module will immediately return to the NORMAL measuring mode.

Switch off the purge air supply.



The Gas Sensing Module will automatically return to the NORMAL measuring mode if NO pushbuttons are operated within 60 seconds.

**Ex**  
**ATEX**  
**M1**  
**GROUP I&II**  
**INTRINSICALLY**  
**SAFE**

INSTALLATION & OPERATING DATA



8 CALIBRATION continued



8.4 Calibrate SPAN



Apply test gas, at a flow rate of 0.2 to 1 l/min, until the display value stabilises.



The Gas Sensing Module will automatically return to the NORMAL measuring mode if NO pushbuttons are operated within 50 seconds.

Press CALIBRATE SPAN until the indicator is flashing YELLOW (3 times).



DO NOT PRESS CALIBRATE SPAN UNTIL THE DISPLAYED VALUE HAS FULLY STABILISED.



The CALIBRATE SPAN will NOT function if the level of gas concentration detected by the sensing element is less than about 25% FULL SCALE. The indicator will NOT flash YELLOW.

Release and the indicator will show RED to denote READY.



Press and hold the calibration pushbuttons to SCROLL the display value UP/DOWN until it concurs with the value of gas concentration marked on the test gas canister.

Switch off the test gas supply.

5 seconds after SCROLLING has ceased the gas sensing module will automatically return to the NORMAL measuring mode.

Re-apply the test gas for a few seconds to verify the response of the sensor.



The Gas Sensing Module will automatically return to the NORMAL measuring mode if NO pushbuttons are operated within 60 seconds.

**Ex**  
ATEX  
M1  
GROUP I&II  
INTRINSICALLY  
SAFE



INSTALLATION & OPERATING DATA



**Ex**  
ATEX  
M1  
GROUP I&II  
INTRINSICALLY  
SAFE

8 CALIBRATION continued

8.5 Over Range Indication

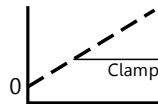
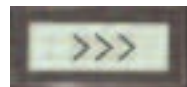
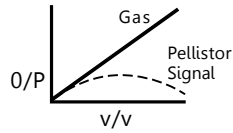

Erroneous readings will be given by a pellistor gas sensing element if it is exposed to gas concentrations that exceed its normal working range of 0 to 5% v/v CH<sub>4</sub>.

The increase in gas concentration displaces the oxygen in the atmosphere so the pellistor becomes progressively less effective, to the point where its output signal actually starts to *decrease* as the gas concentration continues to *increase*.

When OVER RANGE is detected, four conditions will be initiated:

The display will indicate OVER RANGE to prevent ambiguous readings.

The transmitted output signal will be CLAMPED at FULL SCALE to prevent an ambiguous output signal from being transmitted.

The STATUS indicator will FLASH alternate RED and GREEN.

The pellistor in the gas sensing module will be switched into a PROTECT state to prevent oxidation damage.

Refer to Section 8.6

RESET

Briefly interrupt the power supply to the sensor to RESET the OVER RANGE condition.

This will only be effective when the gas concentration has receded and the pellistor in the gas sensing module has reset itself from the PROTECT state.

Refer to Section 8.5

8.6 Pellistor Protection



Catalytic combustion sensors can be damaged if exposed to excess concentrations of gas for long periods



If the OVER RANGE condition is initiated the gas sensing module will be switched into the PROTECT state to prevent oxidation damage.

The status indicator will flash RED/GREEN to indicate that the pellistor is the PROTECT state.

The gas sensing module will reset itself to NORMAL operation after 5 minutes if the gas has cleared. It will continue to attempt to reset itself at 5 minute intervals until the gas has cleared.

It will now be necessary to RESET the OVER RANGE condition.

Refer to Section 8.5

**INSTALLATION & OPERATING DATA**

**9 MAINTENANCE**

It is good safety practice to carry out regular preventative maintenance to confirm correct operation. The periodicity for preventative maintenance should be in line with best practice for the industry where the gas sensor is being used and take into consideration local operating conditions.

**9.1 Output Signal**

Check the response of the sensor at pre-determined intervals by injecting a test gas using a Trolex TX6520.32 Gas Test Kit.

Compare the value of the display with the value marked on the test gas canister.

**9.2 Proof Test**

Calibrate the TX6383 using the instructions in Section 8.

Insert an approved test meter into the signal line.

Inject a test gas using a Trolex TX6520.32 Gas Test Kit.

Compare the value on the test meter display with the measured line value.

If the value on the test meter does not match the value on the display:

Recalibrate and then carry out the proof test again

OR

change the gas sensing module, calibrate and then carry out the proof test.

**Refer to Section 8**

**Refer to Section 9.2**

**9.3 Gas Sensing Modules**

The gas sensing modules should be changed at regular intervals to ensure accuracy of response.

The response of the Pellistor sensor will gradually shift due to normal device decay. The average life is about 5 years, influenced mostly by the operating environment and the mean level of exposure to flammable gas during its lifetime.

The shifting response of the cell should be checked at regular intervals particularly on new installations.

**Refer to Section 5.14**

The modules are conveniently replaceable giving a pre-calibrated standardised output signal. They can be changed in seconds.

Service replacement modules can be supplied by our Product Support Department on a regular basis.

Simply insert the new module into the instrument and return the original for checking and calibration.



The sensor will transmit an alarm signal if a replacement gas sensing module is not fitted within 15 seconds.

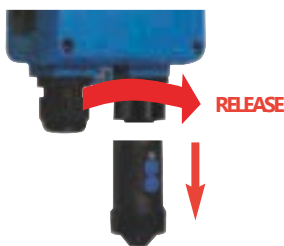
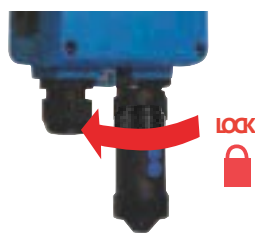
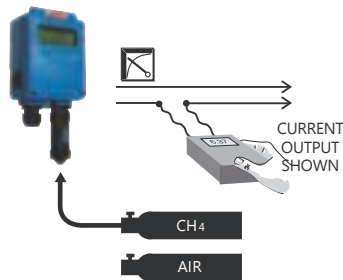
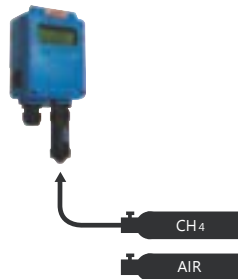
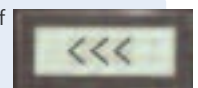

**Ex**  
**A T E X**  
**M 1**  
**GROUP I & II**  
**INTRINSICALLY**  
**SAFE**



**ATEX**  
**M1**  
**GROUP I&II**  
**INTRINSICALLY**  
**SAFE**

**9 MAINTENANCE** continued

**9.4 Annual Safety Check**

The main transmitter itself will not normally require maintenance or calibration but it is advisable to return it to the Trolex Product Support Department for an annual safety check.

**9.5 Damaged Sensors**

A Sensor that has been dropped or damaged in any way should be taken out of service immediately for inspection, repair and re-calibration.

**9.6 Water and Dust ingress (IP)**

IP ratings do not imply that the equipment will detect gas, during and after exposure to those conditions.

If it is suspected that the gas inlet port has been exposed to water in conditions that exceed IPx4, the sensor should be dried and the response of the sensor checked

**9.7 Record Keeping**

Institute a regular calibration and maintenance procedure and keep a record.

Incorrect use of the Sensor or inadequate maintenance may not necessarily be self evident in the Sensor and consequently it must be regularly checked and maintained.



**9.8 Remove Gas Sensing Modules (TX6383.84)**

Insert a bar into one of the radial holes in the gas inlet bush (take care not to damage the internal filter) and unscrew the gas inlet bush.

Remove the filter from the gas inlet bush. Clean or replace the filter as necessary. Fit a new or cleaned filter to the gas inlet bush.

Using a spanner, remove the sensor retaining nut from the remote housing. Remove the gas sensing module from the remote housing. Fit a new gas sensing module to the remote housing, refit the sensor retaining nut and tighten.

Refit the gas inlet bush and tighten using a bar inserted into one of the radial holes, taking care not to damage the filter.



**INSTALLATION & OPERATING DATA**

**9 MAINTENANCE** continued

**9.9 Maintenance and Calibration Log**



ORDER REF <b>TX6383</b>	DATE SUPPLIED
SERIAL No.	USER
GAS TYPE	LOCATION

DATE	SCHEDULED	FAILURE	RE-CALIBRATE	CHANGE GAS SENSING MODULE	RETURN TO MANUFACTURER	COMMENTS

**Ex**  
ATEX  
M1  
GROUP I&II  
INTRINSICALLY  
SAFE

**INSTALLATION & OPERATING DATA**



**10 APPROVALS AND CERTIFICATION**

**10.1 Europe (ATEX)**



Complies with the ATEX directive (2014/34/EU)

TX6383 Flammable Gas Sensor / Transmitter (Group I)

Ex Certificate number: SIRA 01ATEX2299

Ex Certification code: I M1 Ex ia I Ma

TX6383 Flammable Gas Sensor / Transmitter (Group II)

Ex Certificate number: SIRA 02ATEX2300

Ex Certification code: II 2G Ex ia d IIB T4 Gb

**General Conditions for Safe Use**

Prior to installation, it is essential that user refers to the above certificates to ensure that the termination and cable parameters are fully complied with and are compatible with the application. Copies of certificates are available from Trolex.

ATEX Directive (2014/34/EU)

EMC Directive (2014/30/EU)

**10.2 Australia and New Zealand**



TX6383 Flammable Gas Sensor/Transmitter

Ex Certificate Number: ANZEx 12.3021X

Ex Certification Code: Ex ia I

Ex ia d IIB T4

**Conditions for Safe Use:**

Prior to installation, it is essential that the user refers to the above certificate to ensure that the termination and cable parameters are fully complied with and are compatible with the application. Copies of certificates are available from Trolex.

**New South Wales Design Registration**

If the equipment label contains an MDR number, the equipment is design registered. This indicates that the equipment is in conformance with the performance standard, IEC 60079-29-1, as modified by NSW Government regulations.

  
**ATEX**  
**M1**  
**GROUP I&II**  
**INTRINSICALLY**  
**SAFE**



**INSTALLATION & OPERATING DATA**



**10 APPROVALS AND CERTIFICATION continued**

**10.3 Russia (Customs Union)**



Ex certificate number: RU C-GB.AA87.B.00077/19  
 Ex certification codes: PO Ex ia s I Ma V  
 1 Ex ia IIB T4 Gb

**Conditions of Use:**

Prior to installation, it is essential that user refers to the above certificate for any specific conditions of use. The user must ensure that the termination and cable parameters are fully complied with and are compatible with the application. Copies of certificates are available from Trolex.

**10.4 South Africa**



Ex certificate number: MASC MS/11-293  
 Ex certification codes: Ex ia I (-20°C ≤ Ta ≤ +40°C)  
 Ex ia d IIB T4 (-20°C ≤ Ta ≤ +40°C)

**General Conditions for Safe Use**

Prior to installation, it is essential that user refers to the above certificates to ensure that the termination and cable parameters are fully complied with and are compatible with the application. Copies of certificates are available from Trolex.





## 11 FUNCTIONAL SAFETY

### 11.1 Overview of Safety Integrity Level

The following instructions are applicable when the TX6383 Flammable Gas Sensor/Transmitter is used as an element in a safety instrumented function that is specified to achieve a Safety Integrity Level (SIL), eg. SIL 1, 2, etc.

The reliability of the TX6383 Flammable Gas Sensor/Transmitter has been independently assessed in accordance with IEC 61508 for use in SIL applications. The compliance with IEC 61508 includes hardware reliability (probabilistic type failures) and measures to address systematic type failures.

The information that follows forms the 'Safety Manual' required by IEC 61508-2 and is intended to allow correct product selection, system integration, installation, operation and maintenance to enable the SIL specified for the safety instrumented function to be achieved and maintained, as far as the TX6383 Flammable Gas Sensor/Transmitter is concerned.

The actual SIL will depend on many system considerations that are outside the scope of the TX6383 Flammable Gas Sensor/Transmitter and will rely on personnel who are competent in the functional safety aspects of the various lifecycle activities mentioned above.

### 11.2 SIL Suitability

The versions and configurations of the TX6383 Flammable Gas Sensor/Transmitter identified in Table 1 in Section 11.3 below and are suitable for use in gas detection safety functions that have a specified Safety Integrity Level (SIL) in accordance with IEC 61508 or IEC 61511 up to and including:

**SIL 2** - when used in a 'Low Demand' safety function <sup>[1]</sup>

**SIL 1** - when used in a 'High Demand' safety function <sup>[1]</sup>

The functional safety data in Tables 1 and 2 in Section 11.3 must be taken into account by integrators and end-users, including compliance with the restrictions in use (Section 11.4) and all other provisions and conditions in this manual.

System integrators and end users responsible for other lifecycle phases (system specification, integration, installation, commissioning, operation, maintenance, etc) need to perform assessments on the complete scope of their activities to ensure a target SIL for the safety function is and continues to be met.

<sup>[1]</sup> Low Demand and High Demand modes of operation are defined in IEC 61508-4, 3.5.16

**INSTALLATION & OPERATING DATA**



**11 FUNCTIONAL SAFETY** continued

**11.3 Summary of the Verified Functional Safety Data**

The product, configuration and safety manual that have been assessed are shown in Table 1.

Product Information	Details
Product identification	TX6383.01.12/TX6383.84.01.12/TX6383.02.12/TX6383.84.02.12 - Flammable Gas Detector
Product specification	See Section 4 of this manual
Product configuration	4 to 20 mA output Sensor type: CH <sub>4</sub>
System configuration	2/3-wire loop, or 4-wire powered connection; power supply and load as specification (noting Group I certified equipment requirements)
Element safety function	To produce a 4 to 20 mA output that correlates with 0 to 5% v/v concentration range of methane
Safety Manual	See Section 11 of this manual

Table 1 Basic Element Information

The hardware failure data for the TX6383 element safety function based on an extensive analysis of field failure data with a 90% single sided confidence limit is shown in Table 2.

Parameter	Value
Dangerous undiagnosed failure rate ( $\lambda_{DU}$ )	3.5E-07
Dangerous diagnosed failure rate ( $\lambda_{DD}$ )	4.8E-06
Safe failure rate ( $\lambda_s$ )	N/R <sup>[1]</sup>
Safe failure fraction (SFF)	N/R <sup>[1]</sup>
Element type	Type B
Hardware fault tolerance (internal architecture)	0
Diagnostic coverage (DC)	96%
Diagnostic test interval	N/A <sup>[2]</sup>
Probability of Failure on Demand (PFD <sub>AVG</sub> ) <sup>[1 year proof test; 24hr MTTR]</sup>	1.6E-03
Probability of Failure on Demand (PFD <sub>AVG</sub> ) <sup>[3mth proof test; 24hr MTTR]</sup>	5.0E-04
Probability of dangerous Failure per Hour (PFH)	3.5E-07

Table 2 Hardware Failure Data

<sup>[1]</sup> Not required by Route 2H

<sup>[2]</sup> This parameter is determined by the controller being used





## 11 FUNCTIONAL SAFETY *continued*

### 11.4 Conditions or Restrictions for use in SIL Applications

The sections of this Installation and Operating Data manual shall be strictly complied with to ensure validity of the failure data and systematic safety integrity. The following additional restrictions and conditions apply when the unit is used in SIL applications:

1. The host controller must monitor the TX6383 Flammable Gas Sensor/Transmitter output at an appropriate frequency for the application (safety time) and initiate a safe action (eg. process shutdown, evacuation, etc) or be repaired within the MTTR assumed in the PFD calculations shown in the table above if an out-of-range (low) output signal is indicated.
2. If the MTTR or the proof test interval ( $T_1$ ) is different from those assumed in this manual, then the  $PFD_{AVG}$  should be re-calculated and the SIL capability re-verified accordingly (refer to the Safety Manual in Section 11.5 below).
3. The display is for indication only and is not part of the safety function.
4. The environmental limits are restricted to:
  - - 20 to +40°C
  - relative humidity <95%
5. IEC 61508-2, 7.4.4.3.1c limits use to SIL 1 in high or continuous mode of operation when used in a non-redundant configuration.
6. The unit must be calibrated at commissioning and at 3 month intervals during operation and the sensor head replaced as indicated by the calibration check.

### 11.5 Proof Testing

Periodic proof tests of the element safety function must be performed to identify any dormant dangerous failures, particularly when used in 'low demand' safety functions - refer to Section 9.2 of this manual, for the proof test procedure. (Note that calibration alone does not operate the 4 to 20 mA signal). Faults identified by this test must be repaired within the MTTR and the unit returned to full working order.

A suitable proof test interval ( $T_1$ ) should be used in order to achieve the required average probability of failure on demand ( $PFD_{AVG}$ ). A nominal interval of 8,760 hrs (1 year) and Mean Time to Repair (MTTR) of 24 hours has been used in the derivation of  $PFD_{AVG}$  for illustration purposes. If different values are used, the  $PFD_{AVG}$  for a non-redundant arrangement (ie. where the safety function relies on a single element) can be re-calculated as follows:

$$PFD_{AVG} = (\lambda_{DU} + \lambda_{DD}) t_{CE}$$

Where  $t_{CE}$  (the channel equivalent down time) =  $(\lambda_{DU}/\lambda_D) (T_1/2 + MTTR) + (\lambda_{DD}/\lambda_D) MTTR$

For redundant arrangements refer to IEC 61508-6 for the equations.



Those responsible for specifying proof testing of safety functions should refer to IEC 61508-6:2010 clause B.3.2.5 for considerations of the effect of non-perfect proof tests.

**INSTALLATION & OPERATING DATA**



**11 FUNCTIONAL SAFETY** continued

**11.6 System Configuration Drawing**

The illustration below shows how the TX6383 is to be used with other system elements.



If a controller other than the TX9042 is used then the out of range (fault indication) signal from the TX6383 must be detected and acted upon to assert a system fault.

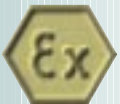

**ATEX**  
**M1**  
**GROUP I&II**  
**INTRINSICALLY**  
**SAFE**