

## High Visibility Methane Monitor

Safety monitoring of methane gas hazards in mining and tunnelling

**Environments:** Mining • Tunnelling • Mineral extraction and monitoring • Hazardous areas

### Features

- High-accuracy, catalytic combustion gas sensor
- High-visibility safety monitoring of methane gas hazards in mining and tunnelling applications
- High-visibility illuminated display
- High-strength moulded housing
- Arduous duty in exposed locations
- Convenient and secure zero and span calibration
- Ex ia Group I approved to operate with standard approved 12 V dc mining power supplies
- Available with a directly mounted gas sensing module, or with a remote gas sensing head, with flexible armoured conduit up to 10 m long

### Benefits

- Quick-release gas sensing head means quick replacement and maintenance
- High-brightness seven-segment LED display readout with 20 mm characters coupled with the proven Trolex gas sensing technology, gives high-visibility information of gas concentration even in totally dark conditions
- Robust housing is sealed against dust and moisture to IP65 standard and is EMC protected
- Remote gas sensing head for convenient mounting where space to fit sensors is restricted
- Two adjustable set-point output contacts with LED status indicators for controlling local plant equipment and alarm warning devices



TX6386 with directly mounted gas sensing head

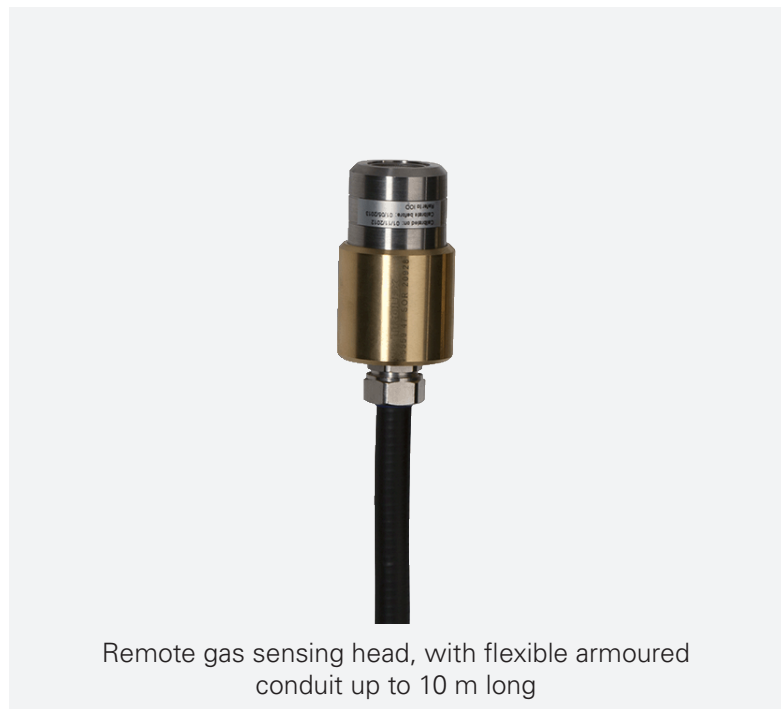

Remote gas sensing head, with flexible armoured conduit up to 10 m long

## Functional Overview

The robust moulded polymer housing of the gas sensor is dustproof and waterproof. It uses a poison-resistant catalytic combustion sensor to monitor flammable gases present in the atmosphere.

The sensor responds to most flammable gases and vapours to varying degrees and is normally calibrated to methane in terms of % volume.

The relatively large mass of the sensing element assures a long and reliable operating life with exceptional stability, even in conditions of high vibration. The natural life of the sensor is about five years depending upon the monitoring conditions and it can be quickly replaced and serviced at the end of its operating life.

You can easily view gas concentration on the bright light emitting display, even in extremely low ambient light conditions.

Trolex can provide calibration for other flammable gases.

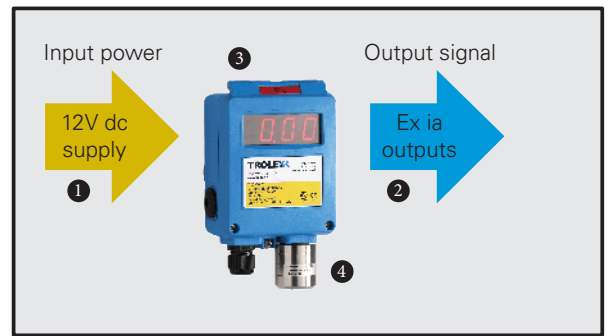

**Hazardous area**

## Technical Information

① <b>Supply:</b>	8.5 to 14.4 V dc	
<b>Current consumption:</b>	160 mA (typical)	
② <b>Output:</b>	2 normally open contacts (held closed when system is healthy)	
<b>Alarm output contacts:</b>	Contact rating:	Maximum current: 1 A Maximum voltage: 230 V ac
		Suitable for switching approved intrinsically safe circuits
		RL1: Independently adjustable setpoint for warning alarm RL2: Independently adjustable setpoint for high alarm
<b>Electrical connections:</b>	4 mm barrier / clamp terminals 2 x M20 x 1.5 cable entries	
<b>Display:</b>	7 segment, high brightness LED	
<b>Ambient temperature limits:</b>	-10 to +40°C	
<b>Humidity:</b>	95% non-condensing	
<b>Storage temperature limits:</b>	-20 to +60°C	
<b>Ambient pressure limits:</b>	1 bar ± 100 mbar absolute	
<b>Vibration limits (BS2011):</b>	10 to 100 Hz:	0.25 mm peak
	100 to 600 Hz:	2 g peak
③ <b>Housing materials:</b>	Housing:	Polycarbonate / ABS
	Gas sensor:	Direct: Machined stainless steel Remote: Machined stainless steel and brass
	Gas sensor connection:	Flexible armoured conduit, PVC coated
<b>Protection classification:</b>	Housing:	IP65
	Gas inlet port:	IP54
<b>Weight:</b>	450 g	
<b>Impact limits:</b>	20 joules (housing)	

## 4 Gas Sensing Module

Sensing range:	0 to 4% v/v. Calibrated for Methane (CH <sub>4</sub> )
Sensing principle:	Catalytic combustion
Linearity:	Linear: 0 to 3% v/v ± 0.2% v/v: 3 to 4% v/v
Drift :	± 0.25% v/v per month (at 25°C)
Response time (T90)*:	< 20 seconds
Warm up time:	< 5 minutes in air or 1% v/v CH <sub>4</sub> (to 95% stated accuracy)
Operating life:	> 5 years**

\* T90 = Time to 90% of final value: \*\* In clean air

## Dimensions

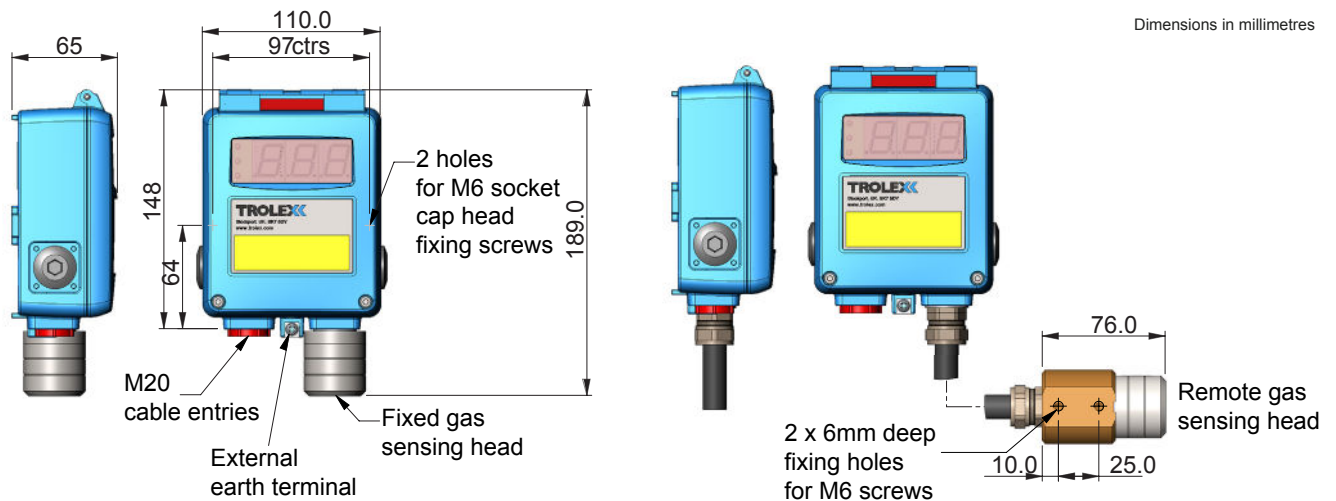

## Connections

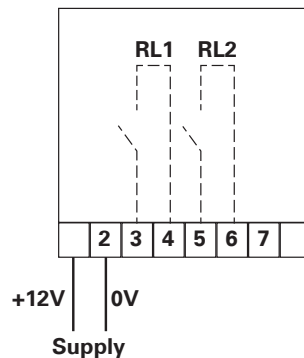

RL1: Setpoint 1 - Warning alarm  
RL2: Setpoint 2 - High alarm

Note: Contacts shown in the alarm or de-energised condition.



# TX6386 Data Sheet

## Order Reference

- TX6386.83 High visibility methane monitor with directly mounted gas sensing module.
- TX6386.84 High visibility methane monitor with remote gas sensing module.

Please contact the Trolex Sales Team for further information and advice:

+44 (0)161 483 1435  
sales@trolex.com



## Certifications

### Ex certified for Group I applications:



#### Europe:

Ex Certificate Number: Baseefa 12ATEX0060  
Certification Code: I M1 Ex ia I Ma



ATEX directive 94/9/EC



#### Australia (IECEX):

Ex Certificate number: IECEX TSA 11.0047X  
Certification Code: Ex ia I Ma



#### Russia (Customs Union):

Ex Certificate number: TC RU C-GB.ГБ05.В.00356  
Certification Code: PO Ex ia I Ma

## Copyright and Trademarks

© 2015 Trolex® Limited.

Trolex is a registered trademark of Trolex Limited. The use of all trademarks in this document is acknowledged.

**Document history:**

Issue 03	6 May 2014	Third publication of this document
Issue 04	10 June 2015	Fourth publication of this document

### Trolex Limited

Newby Road, Hazel Grove, Stockport, Cheshire SK7 5DY, United Kingdom  
+44 (0)161 483 1435 sales@trolex.com www.trolex.com