

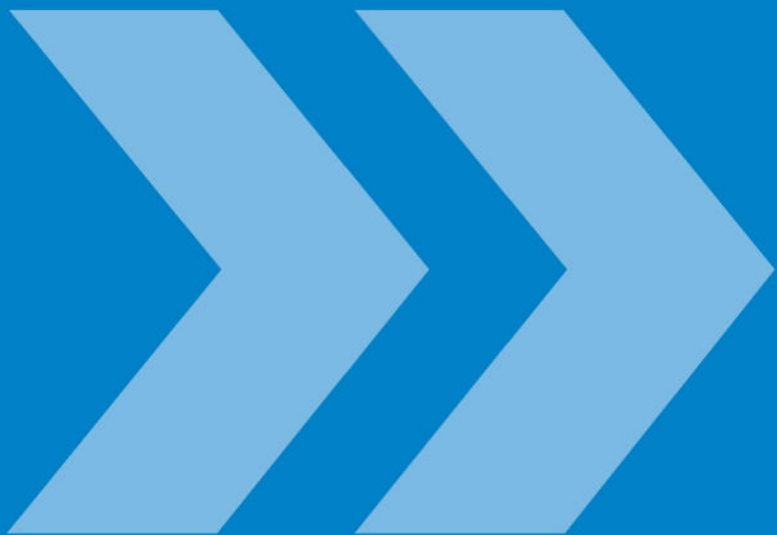

TX9042

Programmable Sensor Controller



TROLEX <<

User Manual

TX9042 Programmable Sensor Controller (PSC)

Contents

1.	Product Overview	4	4.6.5	Cable Distance for Voltage	28
1.1	Operating Features	4		Inputs (0.4 to 2 V)	29
1.2	Application	5	4.6.6	Dual Input Signals (Differential)	29
1.3	Product Options	6	5.	Setup and Calibration	30
1.3.1	TX9042 PSC Input Module Types	6	5.1	Controls and Indicators	30
1.4	Dimensions	7	5.2	Power-up	32
1.5	Technical Information	7	5.3	Signal Display	32
1.6	Electrical Details	9	5.4	Reviewing the Input Module	
2.	Certification & Conformity	10		Configuration	33
3.	Functional Safety	13	5.5	Close-up Information Display	33
3.1	Overview of Safety Integrity Level	13	5.5.1	Close-up1 Display	34
3.2	SIL Suitability	13	5.5.1.1	Close-up 1 Display for an	
3.3	Summary of the Verified			Analogue Input Module	34
	Functional Safety Data	14	5.5.1.2	Close-up 1 Display for a	
3.4	Conditions or Restrictions for			Digital Input Module	36
	use in SIL Applications	15	5.5.2	Close-up 2 Display	37
3.5	Proof Test	16	5.5.2.1	Close-up 2 Display for an	
3.6	System Configuration Drawing	17		Analogue Input Channel	37
4.	Installation	18	5.5.2.2	Close-up-2 Display for a	
4.1	Precautions	18		Digital Input Channel	38
4.2	Labelling	18	5.6	Menu of Functions	39
4.3	Tools & Test Equipment Required	19	5.6.1	Default Values	39
4.4	Mechanical Installation	19	5.6.2	Programming the Operating	
4.5	Connections	20		Values	39
4.6	Input Channel Configuration	22	5.7	Main Menu	40
4.6.1	Analogue Input Modules	23	5.7.1	Main Setup	41
4.6.2	Display of Connection Details	28	5.7.2	Escape/Return	
4.6.3	Replacing an Input Module	28	5.7.3	Communications Setup	42
4.6.4	Cable Distance for Loop Powered		5.7.4	Clock	44
	4 to 20 mA Sensors	28	5.7.5	Keystore Security	44

5.7.6	Datalog Interval Period	45	5.9.4	Fault Signal Alarm Assignment	70
5.7.7	Datalog Display Review	45	5.9.5	Threshold Acceptance Level	71
5.7.8	Clear the Data in the Datalog	46	5.9.6	Keycode Security for Each Channel - 1 to 8	72
5.7.9	Relay Reset Mode Options	47	5.9.7	Digital Level	74
5.7.10	Relay Voting	48	5.9.8	Setting a Digital Failsafe Input Module	75
5.7.11	Relay Operation	50	5.9.9	Channel Display Mode	78
5.7.12	Software Version	50	5.10	Datacommunications	79
5.7.13	Self Test	50	5.10.1	RS485	79
5.7.14	Display Cycling	51	6.	Maintenance	81
5.8	Contrast Control	51	6.1	TX9042 PSC Planned Preventative Maintenance	81
5.9	Channel Function and Calibration	52	6.1.1	Overview	81
5.9.1	Power On Delay (POD) Period	53	6.1.2	TX9042 PSC - Physical Check	81
5.9.2	Scale and Display Settings	55	6.1.3	TX9042 PSC - Replace the battery	83
5.9.2.1	Reset Peak	56	6.1.4	TX9042 PSC - Proof Test	83
5.9.2.2	Constant	56	6.2	TX9042 PSC - Repair	86
5.9.2.3	Update	57	6.3	Maintenance Records	86
5.9.2.4	Units	59	6.4	Maintenance Log	87
5.9.2.5	Decimal Points	59	7.	Disposal	88
5.9.2.6	Lower	60		Disclaimers	89
5.9.2.7	Upper	60		Trademarks	89
5.9.2.8	Calibrate (Temperature Input Module)	61		Document History	89
5.9.2.9	Identification	63		Contact Details	89
5.9.2.10	Connections	63			
5.9.3	Setpoint Characteristics	64			
5.9.3.1	Level	65			
5.9.3.2	Hysteresis	65			
5.9.3.3	Alarm (Rising/Falling)	66			
5.9.3.4	Setpoint On Delay	66			
5.9.3.5	Setpoint Off Delay	67			
5.9.3.6	Operation	67			
5.9.3.7	Relays	69			

1. Product Overview

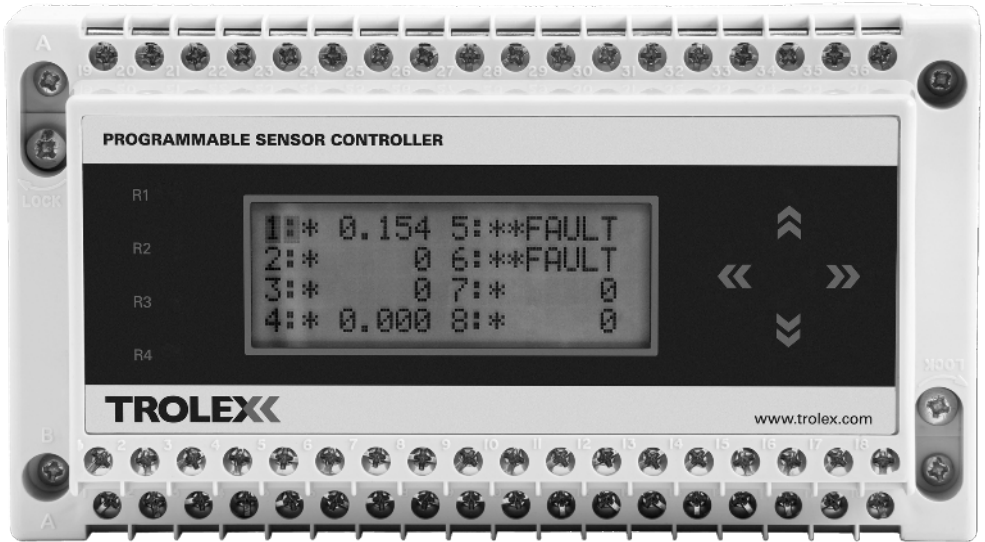

TX9042.55	Up to 8 analogue or digital inputs. Up to 16 On/Off inputs RS485 data communications Data logging facility for up to 26,000 input readings per channel
-----------	---

1.1 Operating Features

- Up to eight channels of analogue or digital inputs or sixteen on/off inputs
- Input and output functions are programmed directly using the keypad
- RS485 data protocol for integrating multi-point sensor collecting into mine wide systems
- Accepts analogue or digital inputs from a variety of source types
- Simple to use, just four keys to programme the TX9042 PSC, no special software and no software programming skills required
- Full functional compatibility with the entire range of Trolex sensors
- Up to 32 TX9042 PSC can be connected to a single mine wide data system

1.2 Application

The TX9042 Programmable Sensor Controller (PSC) is for sensor management and data communications in arduous industrial environments and hazardous areas. It is suitable for use in SIL 1 and SIL 2 applications, in accordance with specific conditions or restrictions.

The uses of the TX9042 PSC include:

- Underground machinery protection
- Environmental monitoring using a combination of gas sensors and flow sensors
- Gas detection systems
- Conveyor control
- Pump and compressor monitoring
- Machine condition monitoring
- Fan vibration monitoring
- ITP monitoring
- On-board underground machinery monitoring
- Plant protection
- Data collection from groups of diverse sensors
- Area network sensor collection and monitoring

The data logging facility can be used to record operational trends and to analyse events where serious incidents may have occurred. All data acquired can also be transmitted over a communication link to a remote point. The system can also be used for collecting sensor information from several distributed monitoring stations on a mine wide sensor network. Up to 32 sensor collectors can be networked on a data link and communicated to a central control and monitoring computer via the data link.

<p>Intrinsically Safe: TX9042.55</p>	<p>Supply Voltage: 12 V dc from an approved intrinsically safe power source</p>
--	---

1.3 Product Options

TX9042 PSC	General Purpose	Mining Ex ia
12 V dc	-	TX9042.55

1.3.1 TX9042 PSC Input Module Types

Input Module Description	Mining Ex ia Order Code
Current - 0 to 20 mA	P5423.516
Current - 4 to 20 mA	P5423.508
Voltage - 0.4 to 2 V	P5423.509
Flow TX6023 - not Io limited	P5423.552
Flow TX6023 - 4 to 20 mA Io limited	P5423.556
Flow TX6022 - Flow	P5423.528
Flow TX6022 - Pressure	P5423.518
PT100 - -50 to +200°C	P5423.510
ac RMS - 500 Hz to 10 kHz - TX5630	P5423.506.01
ac RMS - 15 to 100 Hz - TX5630	P5423.506.02
Digital 12 V/24 V	P5423.523
Digital Failsafe	P5423.522

1.4 Dimensions

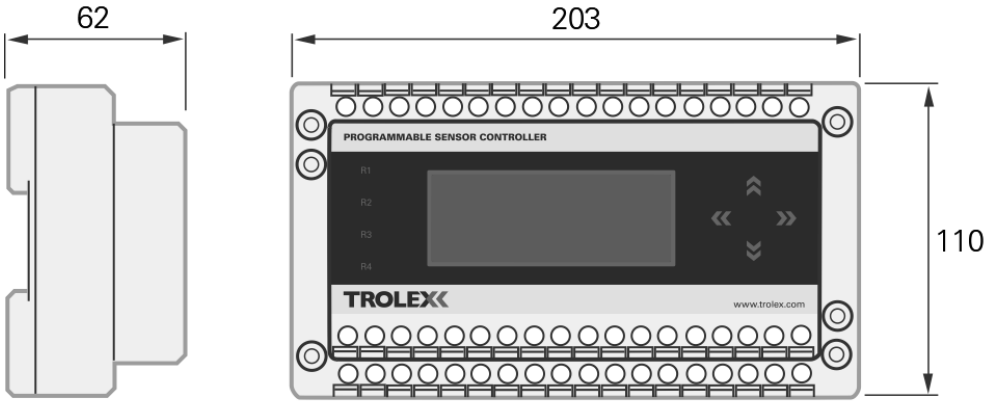

All dimensions in mm

1.5 Technical Information

Display accuracy	+/-0.25% (analogue channels)
Setpoint accuracy	+/-0.5%
Ambient temperature limits	-10 to +40°C
Electrical connections	4 mm barrier/clamp terminals
Housing material	ABS
Nett weight	800 g
Environmental protection	Must be housed in a protective metal enclosure to comply with Intrinsically Safe requirements
Information display	LCD screen 20 characters x 4 lines 6 mm high characters
Mounting	DIN rail
Microprocessor	Microprocessor controlled menu operation, with non-volatile data retention and 10 bit analogue to digital conversion (analogue channels)
Setpoints	2 per channel plus Fault signal

Output relays	4 encapsulated reed relays with function programming
Relay contact rating	200 V 0.25 A 3 W absolute maximum
	<p>Checkpoint</p> <p>Circuits switched by the contacts of the output relays MUST emanate from a certified Intrinsically Safe power source and the circuit parameters must be within Intrinsically Safe requirements.</p>
Setpoint adjustment	0 to 99% of full scale
Hysteresis adjustment	0 to 99%
Power on delay adjustment	0 to 255 seconds for each channel
Output delay adjustment	0 to 18 hours for each setpoint in one second steps
Input update period adjustment	0 to 60 seconds for each channel in 0.05 second steps
Engineering units menu	V, mV, mA, °C, °F, K, g, kg, mbar, bar, Pa, kPa, PSI, %, ppm, %RH, mm, m, mm/s, m ³ /s, rpm, pps, Hz, kHz, secs, m:s, h:m, m/s, m ³ /H, m ³ /m, A, l/m, g/m, l/s, g/s, l/h and g/h
Fault signal	Open or short circuit signal line or sensor fault, will generate a fault signal, the fault will be identified and displayed on the LCD screen
Data communications	RS485 Modbus
Data logging	Up to 26,000 readings with on-demand down loading

1.6 Electrical Details

TX9042.55 - Programmable Sensor Controller (PSC)	
Supply voltage:	12 V dc +20%/-2.5% at 125 mA
Output:	Modbus protocol
Supply current:	125 mA at 12 V
Relay contact rating:	200 V 0.25 A 3 W absolute maximum

Checkpoint
 Circuits switched by the contacts of the output relays **MUST** emanate from a certified Intrinsically Safe power source and the circuit parameters must be within Intrinsically Safe requirements.

2. Certification and Conformity

	ATEX (European Union) certification for use in underground mines (Group I). Complies with ATEX Directive 2014/34/EU.
	Standards: EN IEC 60079-0:2018 IEC 60079-11:2023

	IECEx (International) certification for use in underground mines (Group I).
	Standards: IEC 60079-0:2017 IEC 60079-11:2013

	ANZEx certification for use in underground mines (Group I) in Australia.
--	--

	MASC IA certification for use in underground mines (Group I) in South Africa.
--	---

	EAC certification for use in underground mines in Eurasian Customs Union (including Russia).
--	--

Product Code:	Ex Certificate Number:	Ex Certification Code:
TX9042.xx.xx.19 Programmable Sensor Controller	Baseefa03ATEX0292X IECEx BAS 15.0065X	IM1 Ex ia I Ma Ta = -20°C to +40°C
TX9042.xx.xx.10 Programmable Sensor Controller	ANZEx 06.3057X	Ex ia I Ta = -20°C to +40°C

TX9042.xx.xx.05 Programmable Sensor Controller	MASC M/11-359X Baseefa03ATEX0292X	I M1 Ex ia I Ma Ta = -20°C to +40°C
TX9042.xx.xx.14 Programmable Sensor Controller	RU C-GB.AA87.B.00137/19	PO Ex ia I Ma X Ta = -20°C to +40°C

The following Special conditions for Use apply to the certificates listed above:

Specific Conditions of Use pertaining to Baseefa03ATEX0292X and IECEx BAS 15.0065X are reproduced below. For conditions associated with other certificates listed above, please refer to individual certificates. Copies of certificates are available on www.trox.com.

- i. The Programmable Sensor Controller Type TX9042 must be mounted in a secondary enclosure as shown on drawing P5423.02 or in an alternative metal enclosure (not light alloys) which is appropriately certified as providing a degree of protection of IP54.
- ii. Up to 11 RS485 Comms Modules (in separate Programmable Sensor Controllers type TX9042) may be daisy-chained together (i.e. terminals B1 all linked together, terminals B2 all linked together and terminals B3 all linked together). Provided that the number of daisy-chained PSC's is reduced to 10, these comms lines may be connected to unspecified safe area equipment via an appropriately certified shunt zener diode safety barrier (dual channel a.c.), whose output parameters do not exceed the following per channel:
 - $U_o = 9\text{ V}$, $I_o = 100\text{ mA}$, $P_o = 225\text{ mW}$
 - OR
 - $U_o = 12\text{ V}$, $I_o = 80\text{ mA}$, $P_o = 240\text{ mW}$
 e.g. suitably certified MTL 761, MTL766 to BAS01ATEX7202 or MTL7761ac, MTL7766ac to BAS01ATEX7217.
 For the purposes of this certificate, these shunt zener safety barriers may be considered equivalent to Category I (M1) equipment.
 The cable parameters shall not exceed the following: $C_c = 2.8\text{ }\mu\text{F}$, $L_c/R_c = 222\text{ }\mu\text{H}/\Omega$.
- iii. For the purpose of this certificate, a P+F Cylindrical Inductive Proximity Sensor Type NC... and NJ... to PTB00ATEX2048X to Category II 1G Ex ia IIC T6 connected to terminals T1 to T4 of a Digital Input Module may be considered equivalent to Category I M1 EPL Mb (ATEX) or Ex ia I Mb (IECEx). In this instance, the power supply selected to power the PSC must have an output voltage not exceeding 16 V.

Intrinsic safety parameters

For intrinsic safety parameters associated with certificates listed above, please refer to individual certificates. Copies of certificates are available on www.trox.com.

Installation of equipment

The installation of the product must only be carried out by competent personnel. Each installation needs to be considered with reference to the local safety regulations and authorities. Refer to the following standards for additional guidance:

- IEC/EN 60079-14

- IEC/EN 60079-25

Refer to the Certification Section of this User Manual and to the relevant certificates for any installation parameters and special conditions of safe use.

Commissioning / verification tests prior to first use.

Prior to commissioning and first use, the product shall be inspected for any visible damages and integrity of the enclosure. Never use the product that has damaged housing in hazardous locations.

Maintenance

The maintenance of the product must only be carried out by competent personnel. Maintenance shall be considered with reference to the local safety regulations and authorities. Refer to the following standards for additional guidance:

- IEC/EN 60079-17

It is recommended to periodically check the condition of the product.

The product shall only be serviced and repaired by Trolex Ltd. or a local Trolex service agent approved by Trolex Ltd in order to maintain the explosion protection of the product.

3. Functional Safety

3.1 Overview of Safety Integrity Level

The following instructions are applicable when the TX9042 Programmable Sensor Controller (PSC) is used as an element in a safety instrumented function that is specified to achieve a Safety Integrity Level (SIL), eg. SIL 1, 2, etc.

The reliability of the TX9042 Programmable Sensor Controller (PSC) has been independently assessed in accordance with IEC 61508 for use in SIL applications. The compliance with IEC 61508 includes hardware reliability (probabilistic type failures) and measures to address systematic type failures.

The information that follows forms the 'Safety Manual' required by IEC 61508-2 and is intended to allow correct product selection, system integration, installation, operation and maintenance to enable the SIL specified for the safety instrumented function to be achieved and maintained, as far as the TX9042 Programmable Sensor Controller (PSC) is concerned.

The actual SIL will depend on many system considerations that are outside the scope of the TX9042 Programmable Sensor Controller (PSC) and will rely on personnel who are competent in the functional safety aspects of the various lifecycle activities mentioned above.

3.2 SIL Suitability

The versions and configurations of the TX9042 Programmable Sensor Controller (PSC) identified in Table 1 in Section 3.3 below and are suitable for use in safety functions that have a specified Safety Integrity Level (SIL) in accordance with IEC 61508 or IEC 61511 up to and including:

- SIL 2 - when used in a 'Low Demand' safety function ^[1]
with proof test interval of 3 months
- SIL 1 - when used in a 'Low Demand' safety function ^[1]
with proof test interval of 12 months
- SIL 1 - when used in a 'High Demand' safety function ^[1]

The functional safety data in Tables 1 and 2 in Section 3.3 must be taken into account by integrators and end-users, including compliance with the restrictions in use (Section 3.4) and all other provisions and conditions in this User Manual.

System integrators and end users responsible for other lifecycle phases (system specification, integration, installation, commissioning, operation, maintenance, etc) need to perform assessments on the complete scope of their activities to ensure a target SIL for the safety function is and continues to be met.

^[1] Low Demand and High Demand modes of operation are defined in IEC 61508-4, 3.5.16

3.3 Summary of the Verified Functional Safety Data

The product, configuration and Safety Manual that have been assessed are shown in Table 1.

Product Information	Details
Product identification	TX9042.55 Programmable Sensor Controller
Product specification	See Section 1.5 of this User Manual
Product configuration	<p>4 to 20 mA input conditioning modules fitted OR 0.4 to 2 V input conditioning modules fitted</p> <p>To achieve SIL the TX9042 with 4 to 20 mA or 0.4 to 2 V input conditioning modules fitted, must be configured to de-energise an output channel relay if either the input signal transitions a pre-determined alarm threshold or an internal fault is indicated.</p> <p>Neither the display nor the RS-485 data link are part of the specified safety function.</p>
System configuration	Monitoring of signals from devices configured as 2/3-wire current loop devices, 4-wire current inputs with separate power connection, or voltage inputs.
Element safety function	To de-energise an output channel relay (open relay contacts) if either the input signal transitions a pre-determined alarm threshold or an internal fault is indicated.
Safety Manual	See Section 3 of this User Manual

Table 1 Basic Element Information

The hardware failure data for the TX9042 element safety function based on an extensive analysis of field failure data with a 90% single sided confidence limit is shown in Table 2.

Parameter	Value
Dangerous failure rate (λ_D)	2.3E-06
Safe failure rate (λ_S)	N/R ^[1]
Safe failure fraction (SFF)	N/R ^[1]
Element type	Type B
Hardware fault tolerance (internal architecture)	0
Diagnostic coverage (DC)	60%
Diagnostic test interval	N/A ^[2]
Probability of Failure on Demand (PFD _{AVG}) ^[12 month proof test; 24hr MTTR]	1.0E-02 ^[2]
Probability of Failure on Demand (PFD _{AVG}) ^[3 month proof test; 24hr MTTR]	2.6E-03 ^[2]
Probability of dangerous Failure per Hour (PFH)	2.3E-06

Table 2 Hardware Failure Data

^[1] Not required by Route 2_H

^[2] To be conservative, no credit has been taken for the diagnostics

3.4 Conditions or Restrictions for use in SIL Applications

The sections of this User Manual shall be strictly complied with to ensure validity of the failure data and systematic safety integrity. The following additional restrictions and conditions apply when the unit is used in SIL applications:

1. The TX9042 must be repaired within the MTTR assumed in the PFD calculations shown in the table above if an internal fault is detected in the unit.
2. If the MTTR or the proof test interval (T_p) is different from those assumed in this User Manual, then the PFD_{AVG} must be re-calculated and the SIL capability re-verified accordingly (refer to the Safety Manual in Section 3.5 of this User Manual).

3. The display is for indication only and is not part of the safety function; likewise the RS485 communications are not part of the safety function.
4. The environmental limits are restricted to:
 - +20 to +40°C
 - relative humidity <90%
5. IEC 61508-2, 7.4.4.3.1c limits use to SIL 1 in high or continuous mode of operation when used in a non-redundant configuration.

3.5 Proof Test

Periodic Proof Tests of the element safety function must be carried out to identify any dormant failures, particularly when used in 'low demand' safety functions – refer to Section 6.1.4 of this User Manual, for the Proof Test procedure. Faults identified by this Proof Test must be repaired within the MTTR and the unit returned to full working order.

A suitable Proof Test interval (T_1) should be used in order to achieve the required average probability of failure on demand (PFD_{AVG}). A nominal interval of 8,760 hrs (1 year) and Mean Time To Repair (MTTR) of 24 hours has been used in the derivation of PFD_{AVG} for illustration purposes. If different values are used, the PFD_{AVG} for a non-redundant arrangement (i.e., where the safety function relies on a single element) can be re-calculated as follows:

$$PFD_{AVG} = (\lambda_{DU} + \lambda_{DD}) t_{CE}$$

Where t_{CE} (the channel equivalent down time) = $(\lambda_{DU}/\lambda_D) (T_1/2 + MTTR) + (\lambda_{DD}/\lambda_D) MTTR$

For redundant arrangements refer to IEC 61508-6 for the equations.

Checkpoint

Those responsible for specifying proof testing of safety functions should refer to IEC 61508-6:2010 clause B.3.2.5 for considerations of the effect of non-perfect proof tests.

3.6 System Configuration Drawing

The illustration below shows how the TX9042 is to be used with other system elements.

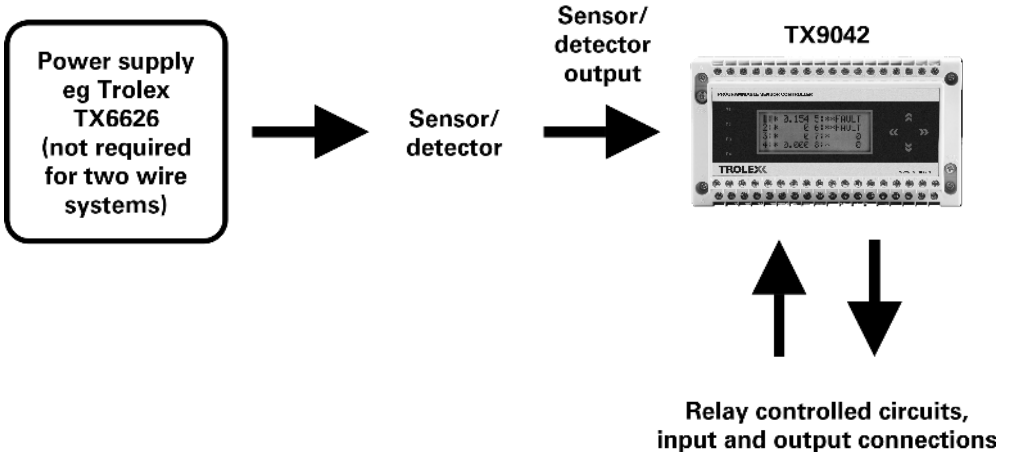

4. Installation

4.1 Precautions

Do not disassemble the TX9042 PSC whilst in the hazardous area or use a TX9042 PSC that has a damaged housing in the hazardous area.

The TX9042 PSC must be installed within a metal protective enclosure to ensure compliance with certification requirements. It is permissible for the enclosure to incorporate a polycarbonate window to allow visibility of the TX9042 PSC LCD screen. However, window area may be no greater than 100 cm².

4.2 Labelling

When the TX9042 PSC is supplied fitted into a standard Trolex TX9204 metal enclosure, two channel identification labels will be fitted to the enclosure near to the connecting terminals. Connection details can also be viewed on the LCD screen, refer to Section 5.9.2.21 for details.

If a TX9042 PSC is supplied to be fitted into a customer supplied metal enclosure, the two channel identification labels will be provided loose and must be fitted adjacent to the connecting terminals in a visible position in order to comply with certification requirements.

Ch 1: Flow	Ch 5: 4 - 20mA
Ch 2: Flow	Ch 6: 4 - 20mA
Ch 3: Flow	Ch 7: 4 - 20mA
Ch 4: Flow	Ch 8: 4 - 20mA

Order Ref.	Serial no.
TX9042.55	21008
A no.	
A023255.01	

Before installation check for the correct channel functions and supply voltage on the channel identification label on the rear of the TX9042 PSC housing.

4.3 Tools and Test Equipment Required

No special tools are needed to assemble or install the TX9042 PSC.

4.4 Mechanical Installation

The TX9042 PSC is installed on a TS35 low profile DIN rail as follows:

1. Loosen the two securing screws, one each at the end of the TX9042 PSC housing.
2. Swing the plastic tabs out of the way.
3. Locate the TX9042 PSC on the DIN rail.
4. Ensure that the plastic tabs can engage behind the DIN rail flange.
5. Tighten the two securing screws.

Do not overtighten the two securing screws.

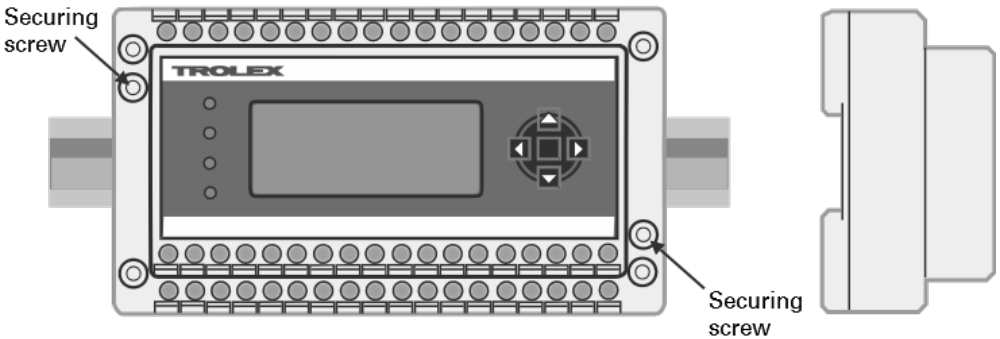

4.5 Connections

The terminals are divided on two horizontal planes. The lower level is used for all input connections and the upper level is used for output signals and data connections.



Input connections - lower level

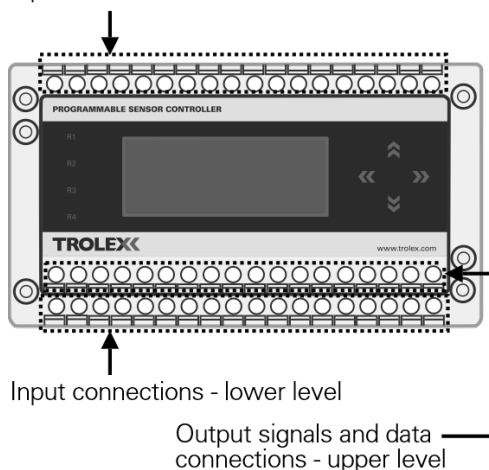

Each of the input channels has four connecting terminals available, and these are utilised in accordance with the type of input module that is fitted (refer to the diagram on the following page).

Channel 1 sensor signal enters on terminals A2 and A3 and if a power supply is required to feed the sensor, then this is available at terminals A1 and A4. The input signal is fully floating and differential, giving high immunity to electrical interference. This configuration is repeated for channels 1 to 8.

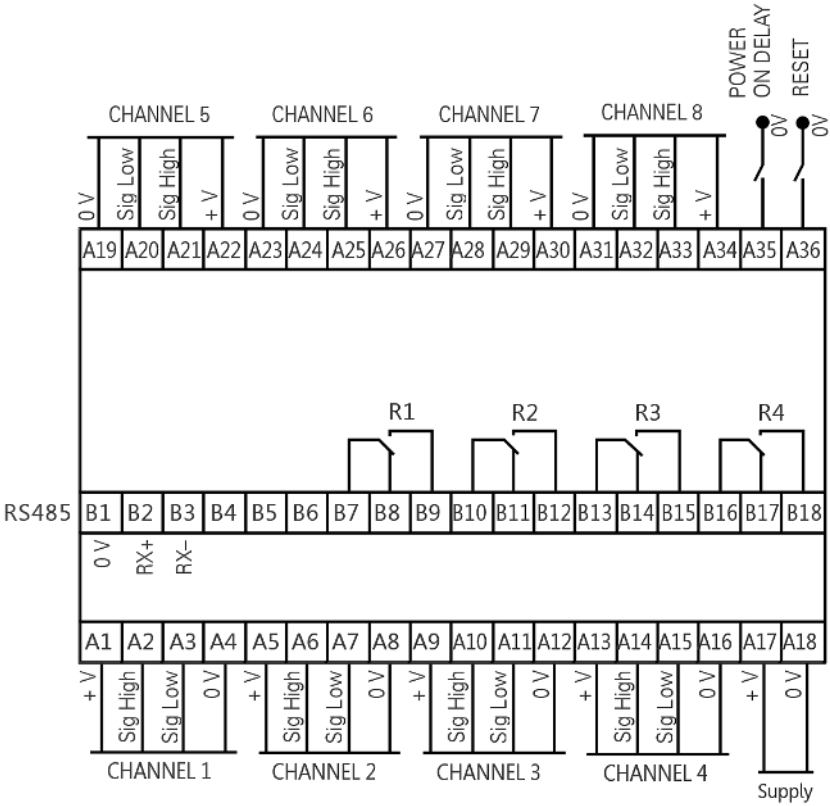

The output contacts are shown with the relays de-energised in the alarm condition

Terminal A35 is used to control the Power On Delay function, see Section 5.9.1 for details, and the External Override facility. Terminal A36 is used to Reset any Latched relays, see Section 5.7.9 for details.

Circuits switched by the contacts of the output relays must emanate from a certified Intrinsically Safe power source and the circuit parameters must be within Intrinsically Safe requirements. The unit must be mounted in a protective metal enclosure to comply with Intrinsically Safe requirements.

Once input channels have been connected to the TX9042 PSC the channel identification labels MUST be completed. Any changes to the input channels MUST be recorded on the channel identification labels.

4.6 Input Channel Configuration

The duty of each of the eight input channels is determined by an interchangeable input conditioning module carried on the main I/O control card.

Each input conditioning module has calibration and functionality information stored in a non-volatile, EPROM. On power-up, the main processor reads this information and sets-up the channel accordingly. The eight input channels of the TX9042 PSC are configured during manufacture for the operational duty required. This is marked on the identification label on the rear of the housing, refer to Section 4.2 for details.

Input conditioning modules can be changed if required, refer to Section 4.6.4 for details. There are two categories of input module type:

- Analogue
- Digital



In total there are 8 possible basic input conditioning modules options for each channel:

Analogue

- Current
- Voltage
- Resistance Temperature Device
- ac Voltage
- Flow Module for TX6023/4
- Failsafe - digital

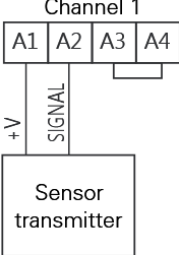
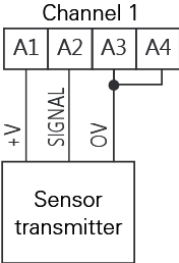
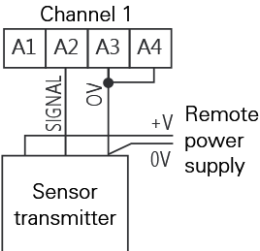
4.6.1 Analogue Input Modules

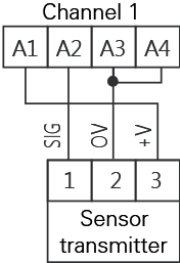
Type of Input	Range	Module Ref	Connections
Current	0 to 20 mA	P5423.516	2 wire loop powered
	4 to 20 mA	P5423.508	
	Impedance 110 R		<p>Channel 1</p>  <p>3 wire control powered</p>  <p>2 wire remote powered</p> 

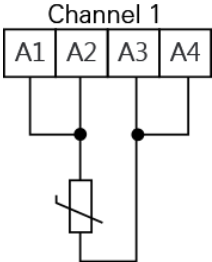
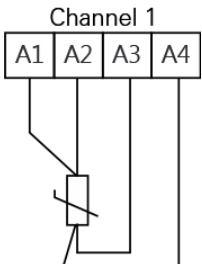
Type of Input	Range	Module Ref	Connections
Voltage 	0 to 2 V 0.4 to 2 V Impedance 100 K	P5423.514 P5423.509	
Resistance Temperature Device 	PT100 -50 to +200°C	P5423.510	2 wire 
Standardised to DIN43760 and BS 1904			4 wire compensated 

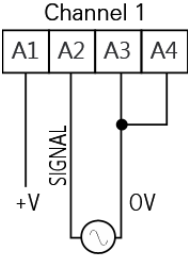
Type of Input	Range	Module Ref	Connections
ac Voltage 	ac RMS Acceleration 500 Hz to 10 kHz 0 to 7g (100 mV/g)	P5423.506.01	
Load cells, ac generators, accelerometers, velocity sensors & power measuring instruments	ac RMS Velocity 15 Hz to 100 Hz 0 to 30 mm/sec (100 mV/g)	P5423.506.02	

Type of Input	Range	Module Ref	Connections
Flow Module for TX6023	For use with: TX6023 + P5546.18	P5423.552	

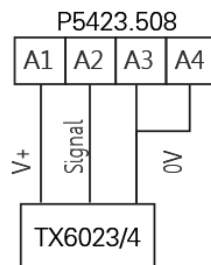
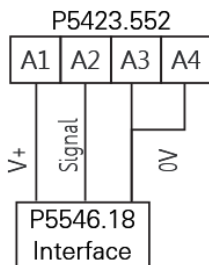
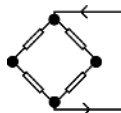

Digital Input (fail-safe)

Type of Input	Range	Module Ref	Connections
Digital - Failsafe	Voltage free contacts with series diode	P5423.522	2 voltage free contacts

On/Off switches connected in series with a diode to give combined open circuit/short circuit sensor connection protection

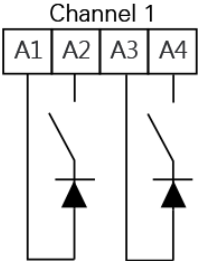
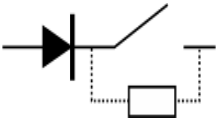

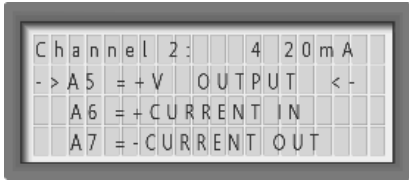

4.6.2 Display of Connection Details

For convenience, input terminal connection details for any channel can be displayed on the LCD screen.

Refer to Section 5.9.2.21 for details.

4.6.3 Replacing an Input Module

The individual channel input conditioning modules are plug-in and can easily be replaced if required, by removing the rear panel of the housing.

The main processor will automatically be re-programmed for the new function of the replacement module.

Checkpoint

Channel input conditioning modules **MUST NOT** be replaced underground.

4.6.4 Cable Distance for Loop Powered 4 to 20 mA Sensors

Maximum cable distance:

$$\frac{V_s - V_{ms}}{0.02 \times R \text{ cable (km)}}$$

V_s	=	Supply Voltage
V_{ms}	=	Minimum Acceptable Sensor Voltage (eg. 16 V)
$R \text{ cable}$	=	Total Resistance of Connecting Cable in ohms/km

4.6.5 Cable Distance for Voltage Inputs (0.4 to 2 V)

The input impedance of the input is very high, so cable distance is usually not a problem.

Voltage drop in the power supply line is the critical factor, particularly on a three wire system where the 0 V of the power supply line is common with the signal line. Use a 4 wire system on distances above 100 m.

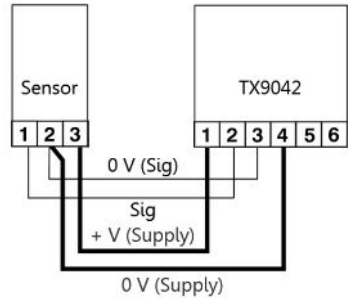

4.6.6 Dual Input Signals (Differential)

The differential input stage of a voltage input module also enables it to monitor two input signals simultaneously and respond to the difference between the two. This technique is frequently used to monitor differential temperature, differential pressure and differential speed.

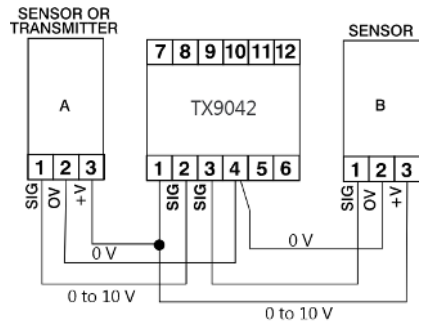

Checkpoint

It is important that the two sensors or input signals are calibrated to the same operating parameters.

5. Setup and Calibration

5.1 Controls and Indicators

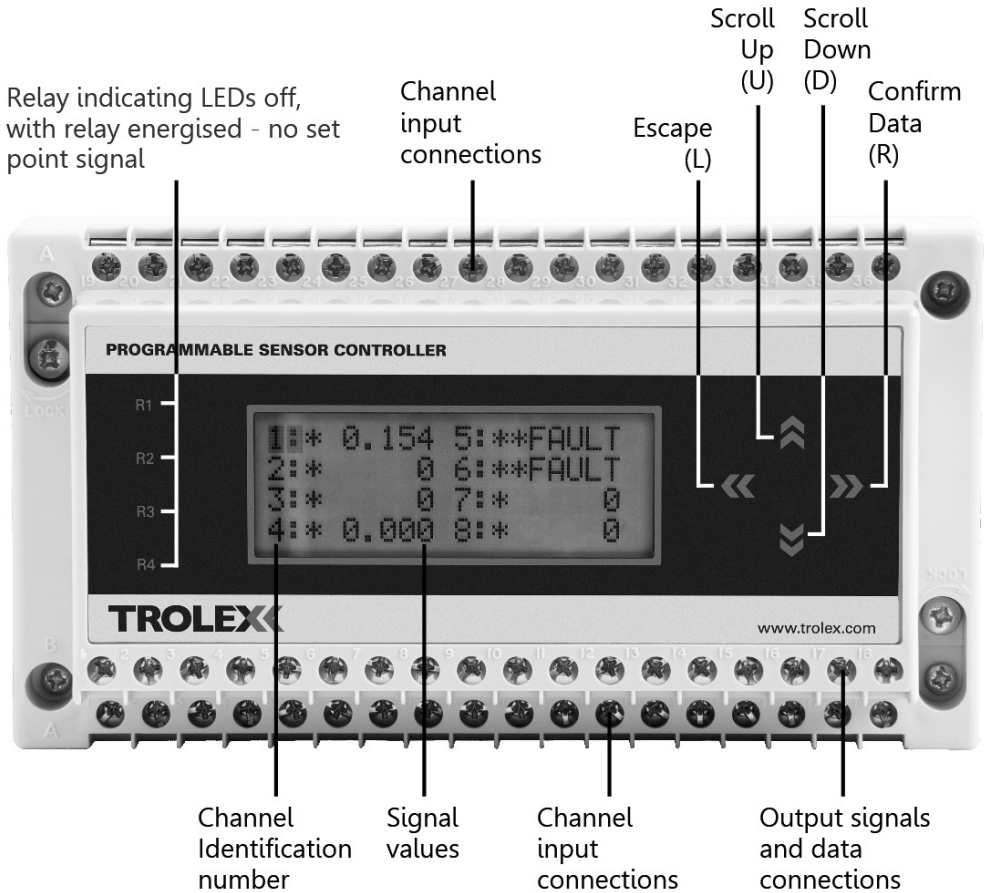

The programming and setting routines for the TX9042 Programmable Sensor Controller (PSC), have been designed for utmost simplicity and the programming system is completely menu driven. There is no special software programme or data input terminal, a PC is not necessary and no computer programming knowledge is required.

There are just 4 keys (the keypad) for controlling the complete operation and the LCD screen provides instructions throughout the programming process. All entries are verified on the LCD screen and incorrect or invalid entries are immediately brought to the attention of the user.

Each data entry on the keypad is acknowledged by a short beep. Hold down the Scroll keys (U or D) for two seconds for rapid self keying.

To use the TX9042 Programmable Sensor Controller (PSC) software and navigate between menus you must press the keypad keys:

- Escape is the Left key - L
- Confirm is the Right key - R
- Scroll Up is the top key - U
- Scroll Down is the bottom key - D

The use of these keys is abbreviated to L, R, U and D throughout this User Manual.

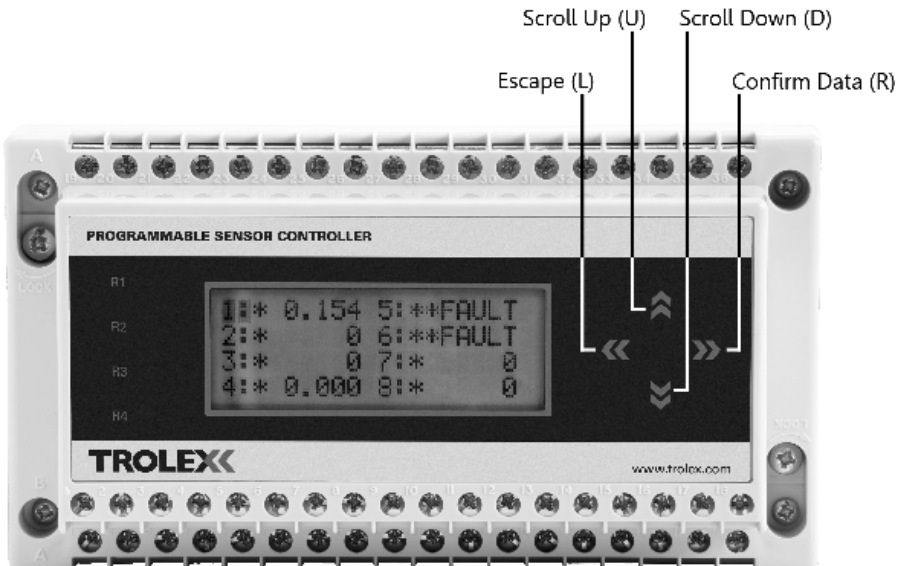

Checkpoint

The TX9042 PSC data memory is permanent. All settings are retained even in the event of power failure.



5.2 Power-up

When first switched on, the processor will initialise all the default values unless new values have previously been programmed. The LCD screen will display the version number of the software currently installed.



5.3 Signal Display

After ten seconds, the screen will switch to the Signal Display mode, displaying the status of all eight channels of input signal simultaneously.



Indicates that a set point has been exceeded on that channel. Refer to Section 5.9.3 for details.



Indicates that a channel input module has not been fitted. Refer to Section 5.4 for details.



Indicates an input signal Error or system Fault on that channel. Refer to Sections 5.4 and 5.9.4 for details.



The flashing cursor frame over the channel identification number indicates that the particular channel is available for individual Close-up examination. Refer to Section 5.5 for details.

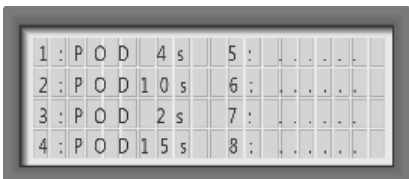

Any channels with Power On Delay (POD) programmed will initially show the length of delay in seconds. Refer to Section 5.9.1 for details. The displayed time will countdown until the POD period is complete, then the screen will revert to the appropriate input signal value in each case.

5.4 Reviewing the Input Module Configuration

The format of the operating data presented on each channel will be automatically determined by whichever input module is fitted.



The input module configuration and the operating mode of each channel can be reviewed from the Signal Display.

Press U and D to review the input module configuration.

Refer to Section 4.6 for details.

5.5 Close-up Information Display

Close-up 1 and Close-up 2 will show more detailed information about a selected individual channel.

Press U or D to navigate the cursor to the selected channel.

Press R to confirm Close-up 1 - (only possible if an input module is fitted on that channel).

Press R again for Close-up 2.

5.5.1 Close-up 1 Display

5.5.1.1 Close-up 1 Display for an Analogue Input Module

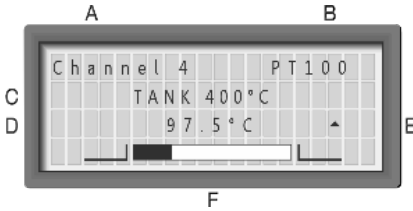

A: Channel identification - 1 to 8.

B: Type of input module (PT100) - this changes to indicate that a channel Setpoint has been exceeded, SP1 and/or SP2.

C: User text entry for channel duty identification and other data such as Full Scale calibration (eg. tank 400°C).

D: Input signal value with appropriate engineering units.

E: Input signal tendency arrows
 = Steady unchanging input signal
 ▲ Rising tendency input signal
 ▼ Falling tendency input signal
 Slowly changing sensor signals under suspicion may be assessed

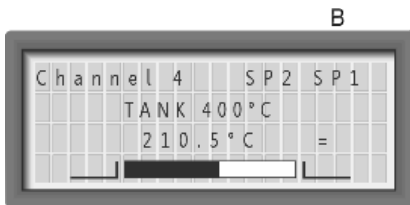

F: Input signal bar graph with limit markers, giving a magnitude comparison of the analogue signal level

Press L to escape and return to the Signal Display.

On an Analogue channel, Close-Up 1 will also display information about any input signal Error condition that has occurred.

A signal that transgresses beyond its normal operating boundaries (ie. above 20 mA or below 4 mA on a 4 to 20 mA input) will initiate warnings at preset levels of discrepancy and trigger exclusive Error signals. Refer to Section 5.9.4 for details.

+5%
Signal exceptionally High (ie. 21 mA)

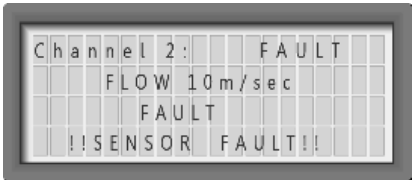

Scale
Signal Over normal scale value (ie. 20.01 mA)



Normal
Normal operating range (ie. 0.4 to 2 V)



Minimum
Signal Under normal minimum value (ie. 3.99 mA) (applies to Signals with offset zero only)

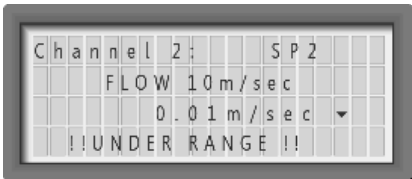



-5%

Signal exceptionally Low (ie. 3.8 mA).

Checkpoint

Digital signals are, by their nature, self monitoring, so this facility does not appear on digital channels.

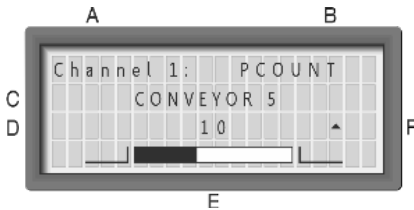

5.5.1.2 Close-up 1 Display for a Digital Input Module

A: Channel identification (1 to 8).

B: Programmed mode of the digital input module (Pcount). This changes to indicate that a channel setpoint has been exceeded (ie. SP1 and/or SP2).

C: User text entry for channel duty identification. (Used to display dynamic function information in some digital modes).

D: Count or frequency to 10 digits (± 999999999).

E: Bar-graph of count or frequency with limit markers giving a magnitude comparison of the count or frequency level.

F: Last count sense indication.
 = Reset or steady input signal
 ▲ Rising count or frequency.
 ▼ Falling count or frequency.

Slowly changing sensor signals under suspicion may be assessed.



Press R to return to the Signal Display.

5.5.2 Close-up 2 Display

Close-up 2 will show information about the setpoint values and historical recorded data relating to the input signal.

From Close-up 1 press L to display Close-up 2.

5.5.2.1 Close-up 2 Display for an Analogue Input Channel

- A: Channel identification (1 to 8).
- B: Type of input module (PT100). This changes to indicate that a channel setpoint has been exceeded (ie. SP1 and/or SP2).
- C: Input signal Level.
- D: The previous Peak signal value recorded since last reset.
- E: The previous Lowest signal value recorded since last reset.
- F: The value of Setpoint 2.
- G: The value of Setpoint 1.
- H: 24 hour clock.

	A			B	
	Channel 4:			PT100	
C	Level:	97.5		09:10	H
D	Pk:	381.5	SP1:	100.0	G
E	Lw:	12.6	SP2:	200.0	F

				B	
	Channel 4:		SP2	SP1	
	Level:	210.5		09:15	
	Pk:	381.5	SP1:	100.0	
	Lw:	12.6	SP2:	200.0	

Press R to return to Close-up 1.

Press L to escape and return to the Signal Display.

5.5.2.2 Close-up 2 Display for a Digital Input Channel

Checkpoint
Not applicable for the Digital level mode.

	A					B		
C	Channel 1:		PCOUNT					H
D	Level:	10		12:15				
E	Pk:	10	SP1:	100			G	
	Lw:	25	SP2:	1000			F	

						B
	Channel 1:		SP2	SP1		
	Level	1435		14:30		
	Pk:	1435	SP1:	100		
	Lw:	25	SP2:	1000		

- A: Channel identification (1 to 8).
- B: Programmed mode of the digital input module (Pcount). This changes to indicate that a channel setpoint has been exceeded (ie. SP1 and/or SP2).
- C: Count or frequency Level.
- D: The previous Peak count or frequency recorded since last reset.
- E: The previous Lowest count or frequency recorded since last reset.
- F: The value of Setpoint 2.
- G: The value of Setpoint 1.
- H: 24 hour clock.

Press R to return to Close-up 1.

Press L to escape and return to the Signal Display.

5.6 Menu of Functions

5.6.1 Default Values

Initial default values are registered into the Menu of Functions during manufacture.

Non-standard default listings can also be entered. This facility can be used to quickly and conveniently programme specific custom operating functions into single or multiple units.

5.6.2 Programming the Operating Values

Normally, the operating values of the various functions in the menu are programmed by the user through the keypad to enter specific calibrations and selections to individual requirements.

The TX9042 supports Modbus register read/write ability, permitting remote configuration of output relay functions on all channels of the Controller, utilising suitable on-site SCADA or PLC programmes:

Setpoint levels.

ON command

OFF command

ON time delay .

OFF time delay

Hysteresis value

NB: Any relay commands generated by the TX9042 Controller will also be functional.

Please contact our Product Support Department assistance is required : +44 161 4831435

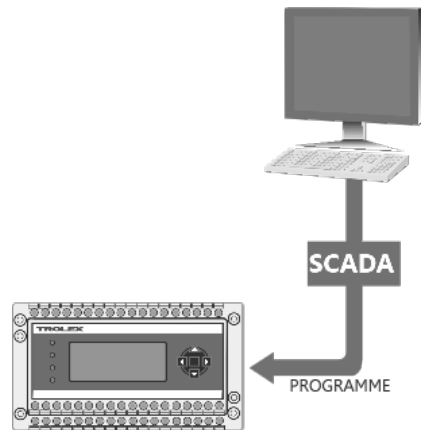

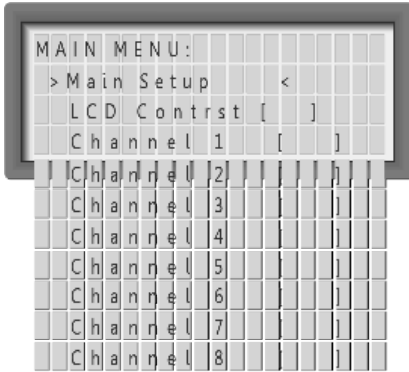

5.7 Main Menu

All the operating functions can be programmed through the keypad by entering the Main Menu.

Entering the Menu

Press L to enter the Main Menu.

Cursor arrows will indicate the first of the function options available in the Main Menu.



If enabled, the Keycode Security lockout will inhibit any further access until the correct entry code is confirmed. Refer to Section 5.7.5 for details.

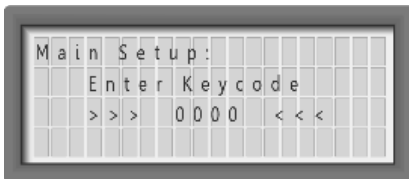

Press D to navigate the cursor along the digits.

Press U to increment the number.

Press R to confirm the selection.



Press L to escape and return to the previous menu.

5.7.1 Main Setup

Press U or D to navigate up and down the menu to the preferred menu.

Press R to confirm the selection. (Previously programmed settings will be displayed alongside each item in a menu).

Function changes can now be programmed as described in the following sections.

Data Saved will flash briefly on the screen whenever a new value is entered during function programming.



Not Saved will flash briefly on the screen if a value is not entered during function programming.



Checkpoint

The screen will automatically return to the Menu being used after a value or selection has been entered.

5.7.2 Escape/Return

Press L to escape and return to the previous menu from any position in the Menu sequence.

Each press of L will revert the screen one step back until the Main Menu is reached.

The screen will progressively step back at 5 second intervals if no keys are pressed.

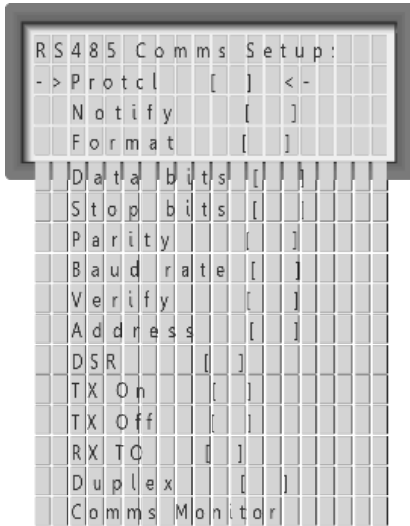

5.7.3 Communications Setup

The characteristics required for the data communications output port can be entered. Datacomms output is RS485. Refer to Section 5.10 for details.

The selections available in some items of this menu list are dependent upon whichever protocol function is selected.

Press U or D to navigate up or down the menu to the preferred menu.

Press R to confirm the selection you have navigated to.

Press U or D to set the value or mode.

Press R to confirm the value or mode.

TxOn - this is the delay between the TX9042 PSC enabling the transmission line and sending data.

TxOff - this is the delay between the end of the received data and disabling of the receive buffer.

RxTO - this is the delay between receipt of last message and reset of the receive buffer.

Data Protocol	Modbus (Binary)	Modbus (ASCII)
Notify	N/A	N/A
Format	Binary	ASCII
Databits	8	7/8
Stopbits	1 to 2	
Parity	None/Odd/Even/Mark/ Space	
Baud Rate	300/600/1200/2400/4800/ 9600/14400/19200/28800/ 57600/115000	
Verify	CRC16	Chksum
Address	1 to 65535	
DSR	Norm / TX High / TX Low	
TX On	0 to 99 ms	
Rx TO	0 to 99 ms	
TX Off	0 to 99 ms	
Duplex	Half/Full	
Comm Monitor	Scrolling display of incoming data stream. Data stream can be stopped and started for closer analysis. Press U to Stop data stream Press D to Start data stream	



Checkpoint

Communication data protocol information and additional application data is available from the Trolex Technical Department.



5.7.4 Clock

Date and time information is used when readings are entered into the Data Log.

Press U or D to navigate to Date or Time.

Press R to confirm the selected function.

Press D to navigate the cursor across the digits.

Press U to change the value of the digit with the cursor underneath.

Press R to confirm the Date or Time.



5.7.5 Keycode Security

Access to menus can be prevented by enabling the Keycode Security function.

It is a selectable function, and the Keycode can be changed as and when required.

Press D to navigate the cursor across the digits.

Press U to change the value of the digit with the cursor underneath.

Press R to confirm the Keycode.

Checkpoint

If more than five invalid entries are attempted, access to the Main Menu will be denied for 30 mins. If you require this feature to be disabled, contact your local Trolex service agent or the Trolex Product Support Department: service@trolex.com

5.7.6 Datalog Interval Period

Each channel of the TX9042 PSC contains a 26,000 point data logging system. This can record the channel number and the Time and Date that an event occurs. The rate or time interval of recording data can be programmed and data is recorded on a first-in/first-out rolling log. Rapid logging is possible to closely capture critical shutdown routines or a catastrophic plant failure.

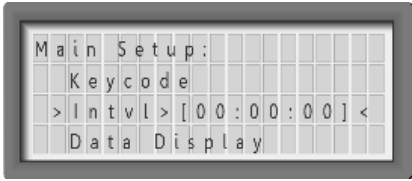

The Interval or frequency at which data is recorded in the log can be programmed in hours/minutes/seconds.

Press D to navigate the cursor along the digits.

Press U to change the value of the digit with the cursor underneath.

Press R to confirm the Interval.

5.7.7 Datalog Display Review

The data recorded in the log can be reviewed on the screen for individual channels.

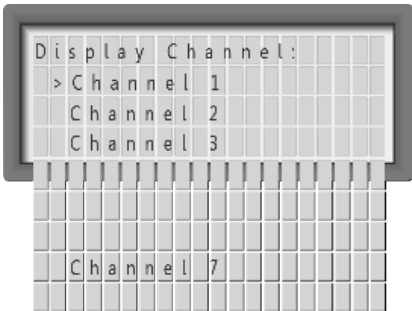

Press U or D to navigate up or down the Channel List to the required Channel.

Press R to confirm the selected Channel.

Press U or D to navigate up or down the Log to the required information.

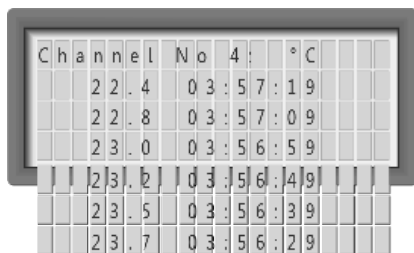

Press R to return to the Channel List.



Supplementary information is displayed momentarily where appropriate:



5.7.8 Clear the Data in the Datalog

Press R to confirm the instruction to clear the Data in the Datalog.

5.7.9 Relay Reset Mode Options

The four output relays, R1, R2, R3 and R4, can be programmed to latch in the alarm condition. Any relays that are latched can be reset in four different ways:

Off: Reset from an external contact or push-button is not possible. This mode is used on critical safety systems, where relays latched in the alarm condition, can only be reset by an authorised person who has access to the keypad of the controller.



High: Any latched relays will be reset as long as the reset input is High (open contact), and the channel input signal has receded from the programmed setpoint level.

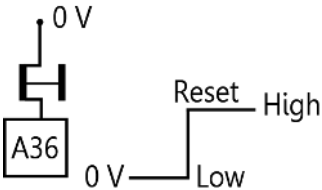

Low: Any latched relays will be reset as long as the reset input is Low (closed contact), and the channel input signal has receded from the programmed setpoint level.

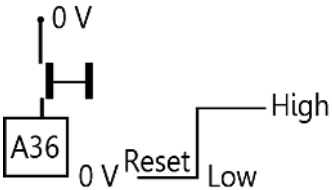

Rise: Any latched relays will be reset only as the reset input Rises (opening pulse contact), and the channel input signal has receded from the programmed setpoint level.

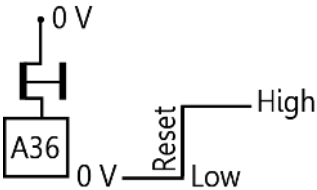

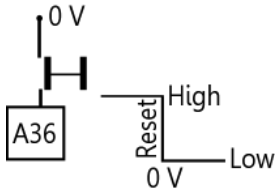

Fall: Any latched relays will be reset only as the reset input Falls (closing pulse contact), and the channel input signal has receded from the programmed setpoint level.

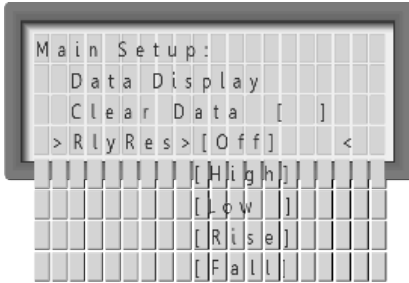

Press U or D to navigate to the mode of reset.

Press R to confirm the mode of reset.

Press L and R to reset any latched relays in all four modes.

Checkpoint
The relay reset input does not affect display counts accumulated on a Pulse Counting channel.

5.7.10 Relay Voting

Each channel of the TX9042 PSC has two adjustable setpoint signals. Any, or all, of these can be matrix programmed to operate any, or all, of the four output relays, R1, R2, R3 and R4.

A Voting system can be superimposed on to this facility, whereby a selectable number of the setpoint signals must be present before the selected output relay will be operated.

Take the example of an environmental monitoring system which must protect against the catastrophic consequences of a flammable gas explosion.

Flammable gas sensors can be installed to detect the presence of the gas and the signals from the sensor can be arranged to trigger setpoint alarm levels in the Programmable Sensor Controller and initiate power shutdown. However, due to the highly complex nature of the process, there are conflicting requirements.

On one hand, for safety reasons, the presence of the gas must be swiftly and unequivocally detected so, triple gas sensors can be fitted in each critical area to achieve this. Conversely, the impact of a false plant shutdown would be financially disastrous and must also be protected against.

In this case, if a Two out of Three voting system is programmed into the Programmable Sensor Controller, the selected output relay will only respond when two or more alarm setpoints are activated together. This ensures that there is at least dual gas monitoring integrity on the plant (and normally, triple monitoring). On the other hand, plant shutdown will only occur when at least two gas sensors are in agreement, so indicating genuine danger.

The programming of this function is completely flexible. Any number of the setpoint signals can be matrixed to a single relay, enabling the selection of the Voting function from any two setpoint signals up to sixteen setpoint signals.

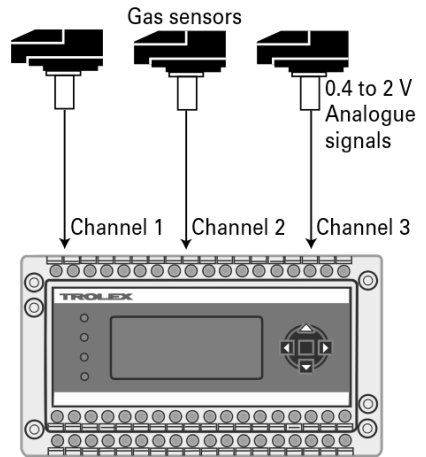



Press U or D to select the Vote Number.

Press R to confirm.

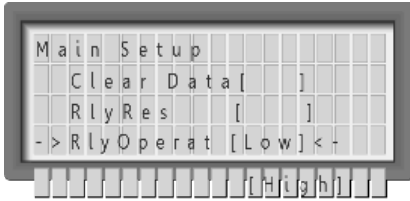

5.7.11 Relay Operation

When relays are not allocated to a setpoint, Relay Operation allows the relays to be left in the de-energised or energised state.

Low = De-energised

High = Energised

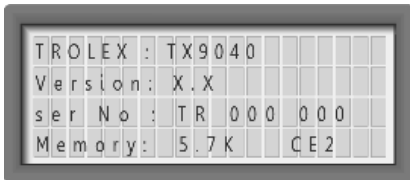

5.7.12 Software Version

Product identification information is presented on the LCD screen, this includes the product reference, software version number, serial number, log data memory and input board type.



5.7.13 Self Test

This enables all the internal functions of the TX9042 PSC to be tested.

5.7.14 Display Cycling

If the user requires more information on each of the inputs, the screen can be set to toggle between screens showing 4 inputs. The rate of toggle can be defined if this is set to zero, logging is disabled.

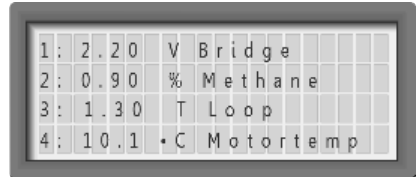

5.8 Contrast Control

The contrast of the LCD screen can be varied to compensate for the effect of local ambient light conditions.

Press U and D to increase or decrease the Contrast setting.

Press R to confirm the selected setting.



Checkpoint

1 is the minimum contrast setting and 15 is the maximum contrast setting.

5.9 Channel Function and Calibration

The operating characteristics of each channel can be individually programmed.

The menu procedure is the same for all eight channels but the contents of the menu will be different for Analogue input modules and Digital input modules.

Checkpoint
If enabled, the Keycode Security will prevent access into individual channels until the correct Keycode is entered.

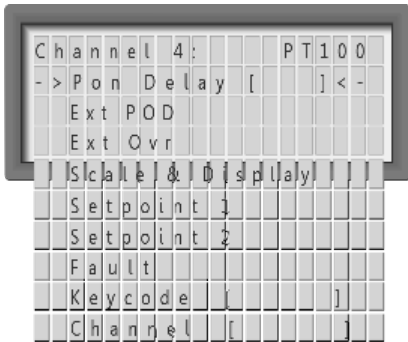

Press U or D to navigate to the mode of Reset required.

Press R to confirm the mode of Reset.

Checkpoint
Terminology in the menu will vary slightly where a digital input module is selected into the Digital Level mode.

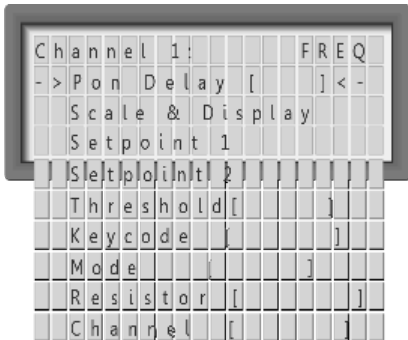

This mode is used for simple On/Off inputs such as thermostats, limit switches or NAMUR proximity sensors.

See the Menu of Functions for individual menu listings. Refer to Section 5.6 for details.

5.9.1 Power On Delay (POD) Period

The setpoint alarm signals SP1 and SP2 can be inhibited for an adjustable time period, after the power is switched on. Each channel can be independently set.



This feature is useful for an initial start-up override when a machine is running up to speed or a process is stabilising.

Checkpoint
The range of configurable values is 0 to 255 seconds.

Press U or D to navigate through the digits to the required POD Period value.

Press R to confirm the POD Period value.

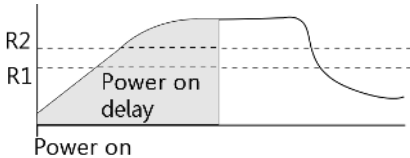

In a situation where the alarm signals need to be inhibited until after an operation has occurred, the Ext POD feature can be used.

A signal on terminal A35 prevents the internal POD timer from operating, at power on, until it is removed.

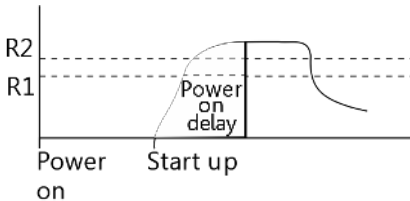
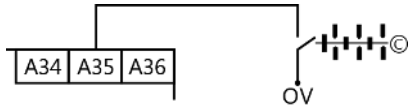

SP2 ALARM

SP1 ALARM

Once the unit is powered up, a signal on terminal A35 can be used to inhibit SP1 and SP2. On release of the signal, SP1 and SP2 are further inhibited by the channel POD period.



External POD can be selected as Off, High or Low.

Off = Disabled

High = Connect to + V to operate

Low = Connect to 0 V to operate

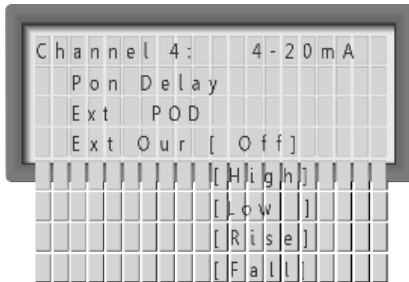

External override can be selected as Off, High Low, Rise or Full.

Off = Disabled

High = Connect to + V to operate

Low = Connect to 0 V to operate

Rise = Positive signal causes internal POD

Fall = Negative signal causes internal POD

5.9.2 Scale and Display Settings

The various characteristics of the signal scale and display can be determined.

The contents of the menu will vary depending upon which type of input module is fitted on the channel being programmed.

Press U or D to navigate to the value required.

Press R to confirm the value selected.

ANALOGUE INPUT MODULE

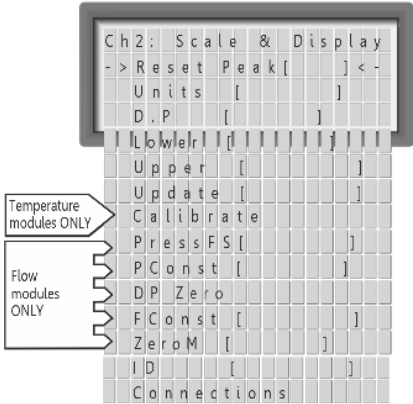

The contents of the menu for a digital input module will vary in relation to which of the sensor operating modes it is set into.

See the Menu of Functions for individual menu listings. Refer to Section 5.6 for details.

DIGITAL INPUT MODULE

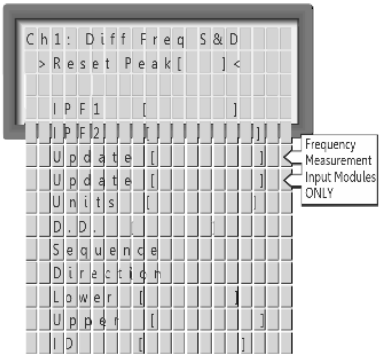



5.9.2.1 Reset Peak

The previous maximum value (Peak) and minimum value (Low) that the signal has reached since the last occasion that it was reset.

Dangerously High or Low sensor conditions may have occurred previously and this feature enables historic trends to be examined.

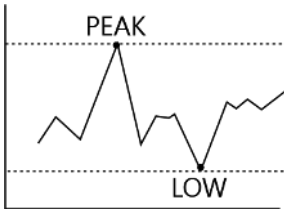

Stored values of previous Peak and Low (max/min) can be deleted.

Press R to select Reset.

Press R to confirm Reset.

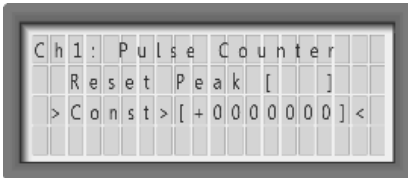

5.9.2.2 Constant

When a Digital Input module is selected into the Pulse Counter mode, an additional item called Constant will appear in the menu choice.

When counting pulses or batch counting, a fixed Constant can be added into the counting register to provide a displaced or elevated starting point as in the case of a tare value or correction factor. This can be a positive or negative quantity and can be applied to all three modes of counting.

It is permanent until re-programmed.

5.9.2.3 Update

The channel input signal is sampled at a pre-determined interval.

The value of an Analogue signal is averaged and updated at periodic intervals and the update period is adjustable. A low setting will give rapid reaction to the input signal and higher settings may be entered where damping of a fluctuating input is necessary, or simply as a means of applying a delay to the input. This is particularly appropriate in electrically noisy environments.

In the case of a Pulse/Frequency input, the microprocessor determines the frequency by counting or Sampling the number of pulses that occur during a timed period.

The longer this sample time is, the more accurate will be the resulting calculation, but there are constraints on this: If the sampling time is too long, the reaction time of the system may be unacceptable.

If an input frequency is fluctuating rapidly, causing instability in the system, the sample time can be adjusted to provide some measure of damping or suppression.

For maximum accuracy, sampling takes place at the front end, prior to pre-scaling.

Press U or D to navigate to the value required.

Press R to confirm the value selected.

Checkpoint

Analogue levels are averaged between samples. Pulse frequencies are averaged between samples.

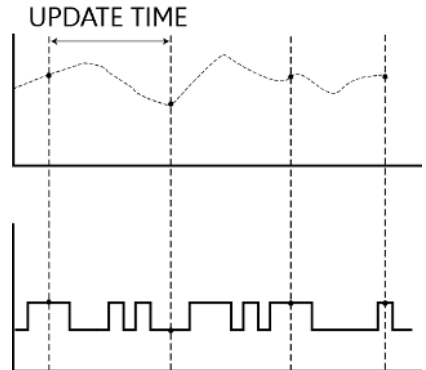



5.9.2.4 Units

A menu of more than 35 standard engineering units is available for adding on to the signal value display to represent the actual parameter being measured, ie. bar, mA, m/sec, °C, etc.

Checkpoint
Where a temperature input module is fitted, the choice will be limited to °C, °F or °K.

Press U or D to navigate to the units required.

Press R to confirm the units selected.

5.9.2.5 Decimal Point

Once the numerical value of the Upper and Lower limits of the display have been set, the decimal point can be navigated to any desired position within the number.

Press U or D to navigate the decimal point to the required position within the number.

Press R to confirm the location selected.

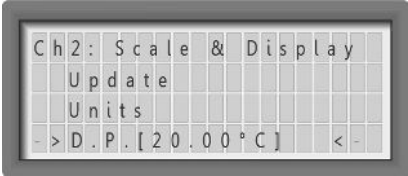

Checkpoint

Any relays that are programmed to Latch will not be reset. Refer to Relay Reset Mode Options in Section 5.7.9 for details.

5.9.2.6 Lower

5.9.2.7 Upper

Independently adjustable, these two items are closely inter-related. They set the desired Lower limit and Upper limit of the display reading for a given input signal. This can be any numeric value through to any positive value. The indicating range from zero to full scale of the display can be programmed to show true unit values incorporating multiplication factors or zero offset values.



Press D to navigate the cursor along the digits to the required digit.

Press U to increment the digit to the required value.

Press R to confirm the value selected.

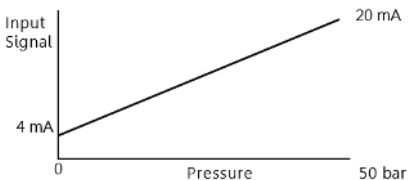

The signal response between Lower and Upper will be assumed to be linear and signals from non conforming devices such as thermocouples will be automatically linearised to the appropriate standard.

Non linear relationships such as square law signals from differential pressure sensors and the polynomials can also be incorporated in software to specific requirements.

It is also possible to interrelate the signals between two separate channels to apply signal differential comparison, correction factors and compensation.

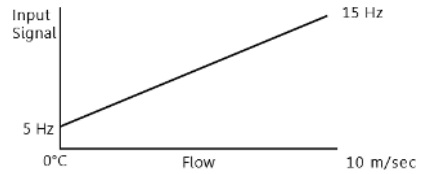

5.9.2.8 Calibrate (Temperature Input Module)

This function only appears in the menu when a temperature input module is fitted.

P5423.72/94 Platinum Resistance
Device - PT100

It sometimes occurs that the temperature/output signal relationship of the temperature sensing device being used is not known. Cable length and size of conductor cores can also affect the calibration of the system.

The display can be calibrated, after installation, to concur with a known temperature applied to the sensor being used.



Press R to confirm the calibration mode.

The screen will show the apparent temperature being measured by the sensor.

Press U or D to increment the value displayed to concur with the temperature measured at the sensor.

Press R to confirm the value selected.

The linearity response of the input module will be automatically corrected, based around the new calibration point entered and the correction factor will be appropriate to whichever type of temperature input module is fitted.

A simple way to apply a known temperature to an installed sensor is to place it in a small cup of ice and calibrate the display to 0°C as described.

5.9.2.9 Identification

Channel identification text can be entered to denote the input duty, the location or the tag reference of the input device.

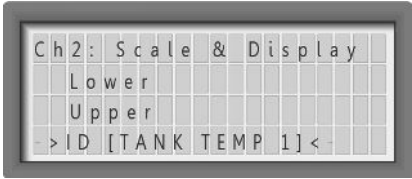

Up to 11 digits of text can be entered into the display and there is a menu of letters, numbers and symbols to choose from, thus enabling channel identification or location data to be entered.

Checkpoint
 User specified text may have been entered during manufacture.

Press D to navigate the cursor along the digits to the required digit.

Press U to increment the digits to the required value.

Press R to confirm the values selected.

5.9.2.11 Connections

Terminal identification details are listed on the display for a particular channel input electrical connections.

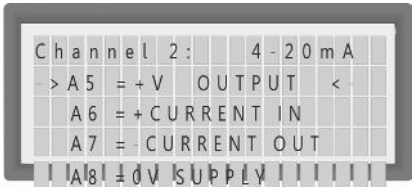

Press U or D to navigate through the data.

Any relays that are programmed to latch will not be reset. Refer to Relay Reset Mode Options in Section 5.7.9 for details.

5.9.3 Setpoint Characteristics

Each of the eight channels has two Setpoint signals or alarm points, SP1 and SP2.

The various operating characteristics of each Setpoint can be individually determined.

Setpoint signals are High in the normal condition and switch to Low when activated, as a Setpoint is exceeded.

The Setpoints do not directly control the four output relays, R1, R2, R3 and R4, but can be matrix programmed to selectively initiate the four relays.

Press U or D to navigate to the menu required.

Press R to confirm the menu selected.

Checkpoint

The contents of the menu for a digital input module will vary slightly depending upon which of the seven operating modes it is set in. Refer to Section 5.9.7 for details.

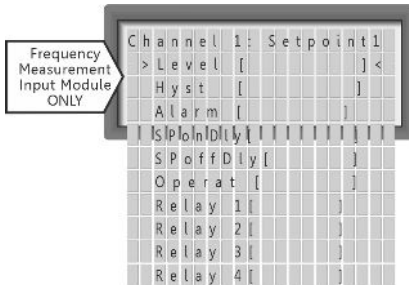
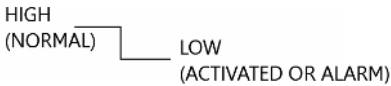

5.9.3.1 Level

The operating level of the setpoint signal can be programmed. This can be set for any numerical value and the polarity can be positive or negative as required.

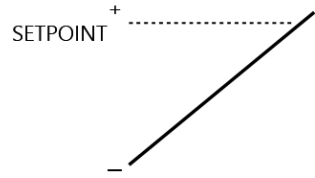

Press D to navigate the cursor along the digits to the required digit.

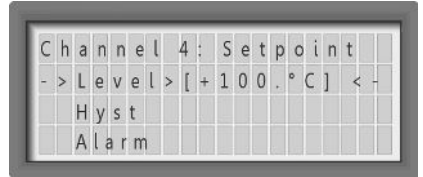

Press U to increment the digits to the required value.

Press R to confirm the Setpoint level.

5.9.3.2 Hysteresis

Hysteresis is the deadband between the setpoint switching On and switching Off as the input signal rises and falls. This can be set as a percentage of the Set Point Level.

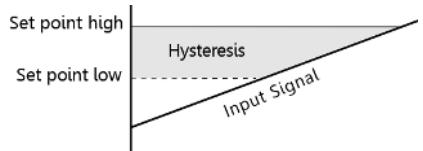

Press U or D to increment the hysteresis value.

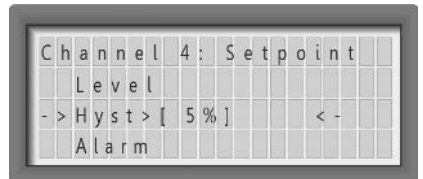

Press R to confirm the Hysteresis value.

A low value of hysteresis, say 5%, is often used to override fluctuating signal levels and to prevent hunting in closed loop control systems.

A high value of hysteresis can also be used as a control function when controlling the operation of pumps. The pump will start at high level (SP1) and continue pumping until low level is reached at the bottom of the hysteresis band.

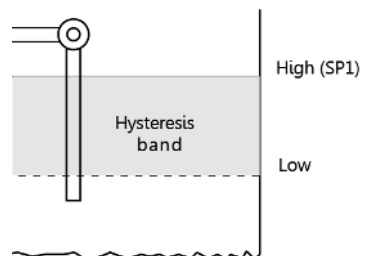

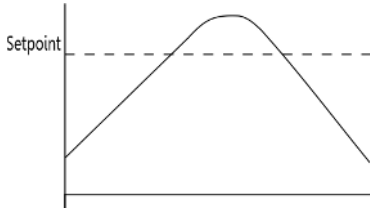

RISING ALARM LOW

FALLING ALARM LOW

5.9.3.3 Alarm (Rising/Falling)

The setpoint signals can be arranged to occur on a rising input signal or a falling input signal. For example, when monitoring excess vibration or high gas concentration, the setpoint signals can be set to activate on a rising signal to give a failsafe alarm function. Conversely, when monitoring flow failure or low pressure, the setpoint signal can be set to activate on a falling signal.

Press U or D to navigate to rising or falling as required.

Press R to confirm the selection.

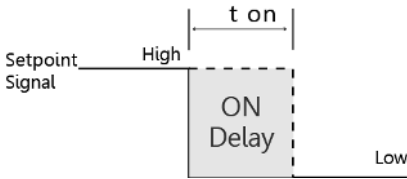
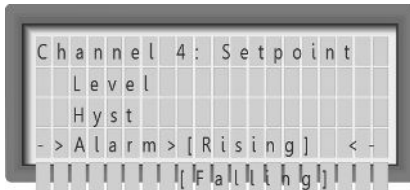

5.9.3.4 Setpoint On Delay

The operation of the Setpoint signal can be delayed by an adjustable time period, T1. This is useful for alarm verification, to apply time delay in a process control action, or to override a spurious fluctuation of the input signal.

If the input signal falls below the setpoint before the programme time has elapsed, the timer will reset to zero, ready to start again.

Press U or D to navigate to the Setpoint On Delay value required.

Press R to confirm the value selected.



5.9.3.5 Setpoint Off Delay

The resetting of the Setpoint signal can also be delayed by an adjustable time period, T2.

If the input signal exceeds the Setpoint before the programme time has elapsed, the timer will reset to zero, ready to start again.

Press U or D to navigate to the Setpoint Off Delay value required.

Press R to confirm the value selected.

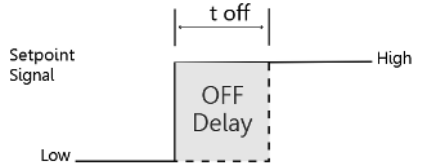

Checkpoint
Both the Setpoint On Delay and the Setpoint Off Delay can be combined, if required, and are independently programmable. Refer to Sections 5.9.3.4 and 5.9.3.5 for details.

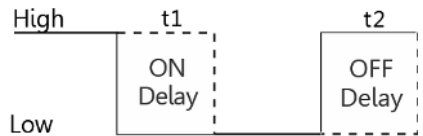

5.9.3.6 Operation

A set point signal can be set to function in four different ways.

Auto Reset - the Setpoint signal will go Low when the input signal exceeds the Setpoint value and will reset when the input signal recedes. T1/T2 = any Setpoint On Delay and/or Setpoint Off Delay that is programmed. Refer to Sections 5.9.3.4 and 5.9.3.5 for details.

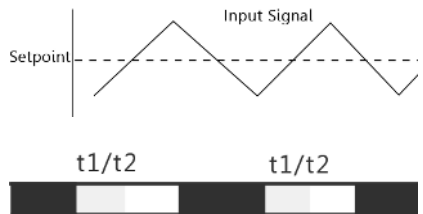

Checkpoint
The reset point will also be influenced by any hysteresis value that is programmed. Refer to Section 5.9.3.2 for details.

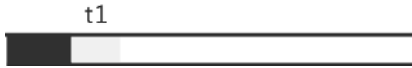

Latch Until Reset - the Setpoint signal will go Low when the input signal exceeds the Setpoint value and latch until reset. T1 = any Setpoint On Delay that is programmed. Refer to Section 5.9.3.4 for details.

Refer to Section 5.7.9 for details of Relay Reset Mode Options.



Toggle - the setpoint signal will go Low/High alternately each time the setpoint value is exceeded. T1/T2 = any Setpoint On Delay and/or Setpoint Off Delay that is programmed.



Pulse - the setpoint signal will give an impulse equal to the T1 time each time the setpoint value is exceeded.



Press U or D to navigate to the required function.

Press R to confirm the function selected.

5.9.3.7 Relays

The TX9042 PSC has four common output relays, R1, R2, R3 and R4.

Any setpoint signal can be assigned to operate any one or all of the relays by selecting Yes or No in each case.

This enables alarm status groupings, selective shutdown routines and logic elementary functions to be created.

Press U or D to navigate to Yes or No as required.

Press R to confirm the selection.

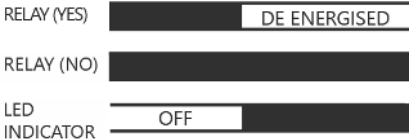

Checkpoint
Any or all of the sixteen setpoint signals can be programmed for Voting operation with the output relays. Refer to Section 5.7.10 for details.

5.9.4 Fault Signal Alarm Assignment

Each of the 8 channels on the TX9042 PSC has a Fault Output Signal which triggers when a system fault is detected by the processor. Refer to Section 5.5 for details. The fault types are:

- Sensor Failure
- Input Signal Faults
- Loss of Signal

The Fault signal from each channel can be cross matrix programmed in the same way as the Set Point signals, to interface with any or all of the four output relays, R1, R2, R3 and R4.

This way, it is possible to identify the character of the alarm without causing unnecessary shutdown, or giving a false alert.

Press U or D to navigate to the relay required.

Press R to confirm the selection.

Press U or D to navigate to Yes or No as required.

Press R to confirm the selection.

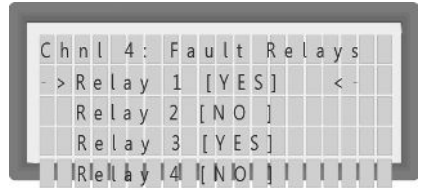

5.9.5 Threshold Acceptance Level

When a Digital Input Module is fitted, the Threshold selection will appear in the Channel Menu.

The input signal threshold voltage level can be set so that only pulse amplitudes above a preset magnitude will be accepted by the input.

Background noise or spurious interference can be eliminated in this way. This is particularly useful in a high speed, pulse processing system where a simple time delay on the pulse would be unacceptably slow.

Press U or D to navigate to the Threshold Acceptance Level value required.

Press R to confirm the value selected.

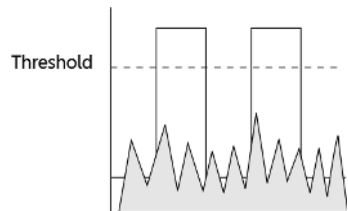
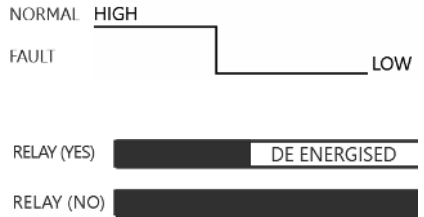

5.9.6 Keycode Security for Each Channel - 1 to 8

The same Keycode number previously entered in the Main Menu can also be used to prevent unauthorised access to any individual channel function programming or to prevent disclosure of programmed parameters.

Each channel can be selectively inhibited so an operator can still have access to adjust other channels where this would be appropriate. Refer to Section 5.7.5 for details.

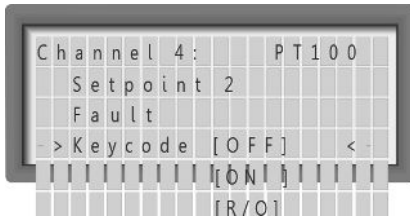

Press U or D to navigate to On or Off as required.

Press R to confirm the selection.

Checkpoint

- Off Programming available
- On Programming inhibited
- R/O Programming read only - parameters are displayed but cannot be changed

Checkpoint

If more than three invalid entries are attempted, access to the channel function programming will be denied for 30 mins. If you require this feature to be disabled, contact the Trolex Product Support Department: service@trolex.com

Close-up 1 Display

Additional dynamic function information is displayed in this mode. Refer to Section 5.5.1 for details.

T - Elapsed time from the last reset pulse on Input 1.

SP1 - Setpoint 1 or target time (Setpoint 2 can also be programmed as a second target time but is not displayed).

Time - Duration of the previous time interval in seconds (32.7 seconds).

Bar Graph - Progressive overview of the length of the time interval between each successive reset pulse on Input 1.

The bottom end of the bar graph (the estimated minimum interval period) is programmed by the Lower setup.

The top end of the bar graph (the estimated maximum interval period) is programmed by the Upper setup.

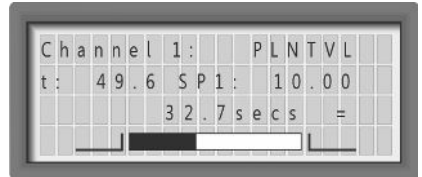

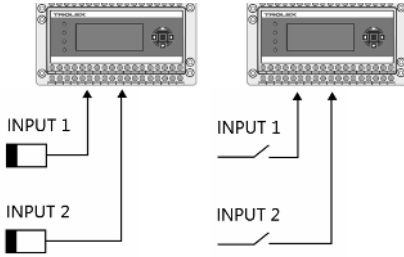

5.9.7 Digital Level

Inputs from simple On/Off switches, voltage free contacts, thermostats, pressure switches, limit switches and NAMUR proximity switches.

Each digital input module will accept two input switches, one on Input 1 and one on Input 2, each of these inputs can be programmed independently for most of the standard functions.

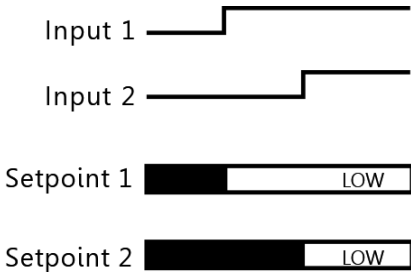

Update time - input delay. Refer to Section 5.9.3.5 for details.

Identification text. Refer to Section 5.9.2.10 for details.

Terminal connections display. Refer to Section 5.9.2.21 for details.

Alarm on high/low input - rising/falling alarm. Refer to Section 5.9.3.3 for details.

Setpoint delay - output delay. Refer to Section 5.9.3.4 for details.

Operation - auto reset/latch/toggle/pulse. Refer to Section 5.9.3.6 for details.

Relay output assignation. Refer to Section 5.9.3.7 for details.

Signal Display

Input 1

Input 2



Close-Up 1 Display

The state of Input 1 and Input 2 is displayed as Low (L) or High (H).

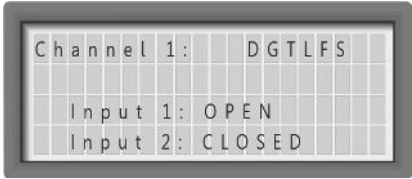

5.9.8 Setting a Digital Failsafe Input Module

A channel fitted with Digital Failsafe input module will show an additional item called Resistor in the channel menu.

The module will accept inputs from simple On/Off switches, voltage free contacts such as thermostats, pressure switches and limit switches, also providing a failsafe capability.

Each digital input module will accept two input switches, one on Input 1, the other on Input 2 and each of these inputs can be programmed independently for most of the standard functions.

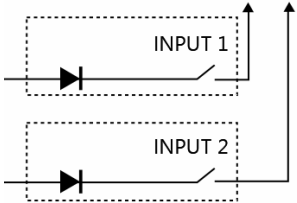
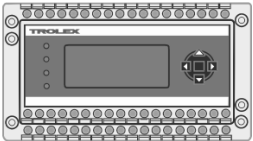

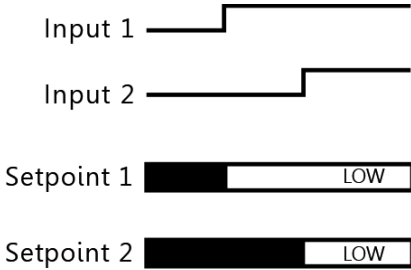

Identification text. Refer to Section 5.9.2.20 for details.

Terminal connections display. Refer to Section 5.9.2.21 for details.

Alarm on high/low input - rising/falling alarm. Refer to Section 5.9.3.3 for details.

Setpoint delay - output delay. Refer to Section 5.9.3.4 for details.

Operation - auto reset/latch/toggle/pulse. Refer to Section 5.9.3.6 for details.

Relay output assignment. Refer to Section 5.9.3.7 for details.

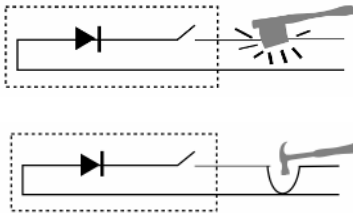

Short Circuit Detection

A diode connected in series with input contacts at the remote point will enable the TX9042 PSC to detect and identify an open short circuit connection in the sensor connecting cable.

An open circuit cable connection such as a severed cable will appear as an open input contact, signifying an alarm in the normal way. A short circuit connection such as a crushed cable will short the diode that is connected in series with the remote input contact, initiating a Fault (F) indication and a Fault channel signal.

Signal Display

Input 1 - Input 2

Refer to Section 5.3 for details.

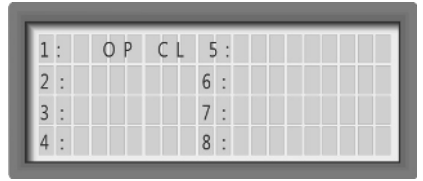

Input contact - Open: OP

Input contact - Closed: CL

Short circuit connection: Fault (*F)

Open circuit connection: Fault (*F)

Close-Up 1 Display

Refer to Section 5.5.1 for details.

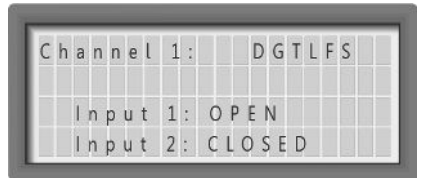

Short Circuit and Open Circuit Detection

The module can be programmed to individually identify both short circuit and open circuit conditions. If a resistor is also incorporated into the remote contact connection, the TX9042 PSC will be able to exclusively identify both failure modes of the connecting cable conditions.

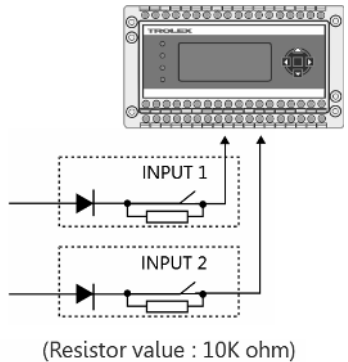

Signal Display

Input 1 - Input 2

Refer to Section 5.3 for details.



Input contact - Open: OP

Input contact - Closed: CL

Short circuit connection: Fault (*F)

Open circuit connection: Fault (*F)

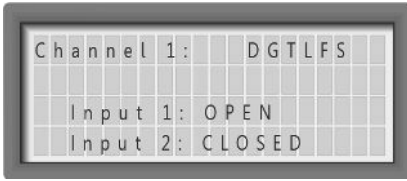

Close-Up 1 Display

Refer to Section 5.5.1 for details.



Press U or D to select the resistor state of Yes or No as required.

Press R to confirm the selection.



5.9.9 Channel Display Mode

Where a channel is out of operation or a system Fault has been diagnosed, the channel can be de-activated. This will be denoted on the Signal Display by Ch OFF.

Press U or D to navigate the Channel Display Mode to On or Off as required.

Press R to confirm the selection.

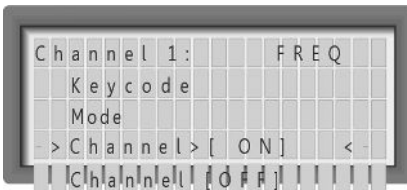

Checkpoint

The channel input will now have no effect on the two related set points SP1 and SP2 or the channel Fault signals.

5.10 Datacommunications

The TX9042 Programmable Sensor Controller (PSC) is equipped with RS485 datacommunications.

5.10.1 RS485

The RS485 communications module can be used for point to point or multidrop data communications up to 2 km operating distance.

Maximum total cable length	2 km
Maximum no. of TX9042 PSC per System	11
End of Line Resistance	120 ohm (between B2 & B3)
Recommended Cable Parameters	<ul style="list-style-type: none"> 1.5 mm² with overall screen 1.5 mm² up to 2 km • 1 twisted pair for data • 0 V • Overall screen
Sensor Controller Datacomms Module	RS485 (55) TX9042

Data Protocol - the communications format setup can be individually programmed through the keypad for PC system compatibility and data protocol information is available from the Trolex Technical Department. Refer to Section 5.7.3 for details.

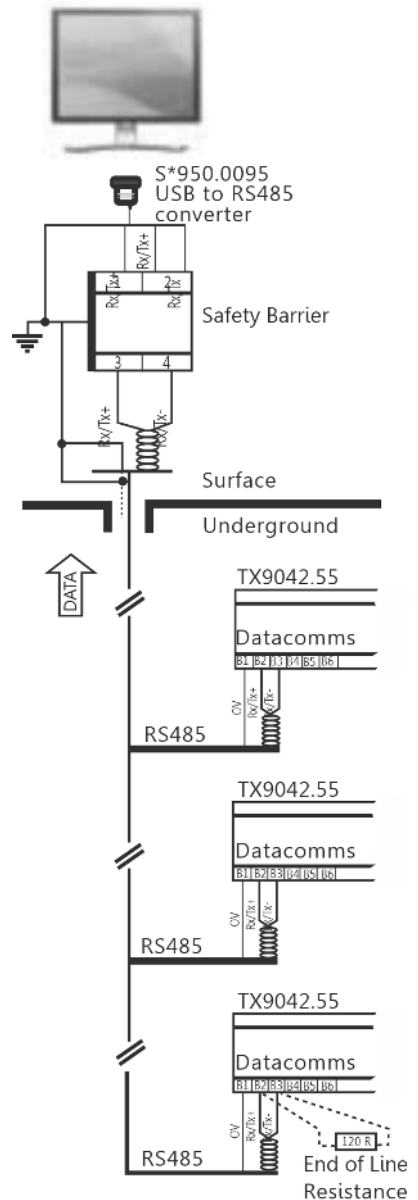

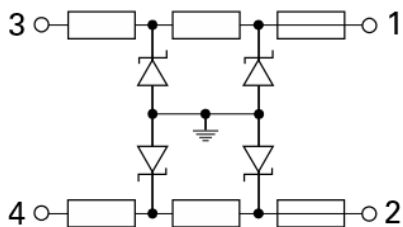
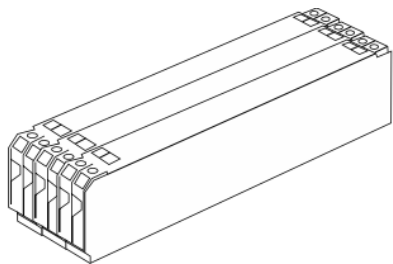

Checkpoint

When the data transmission system extends into a safe area, it must be used with an approved safety barrier to comply with intrinsic safety regulations.

Please contact the Trolex Sales Team for further information and advice on suitable safety barriers. sales@trolex.com

Please refer to Section 2. Certification and Conformity for additional details.

6. Maintenance

6.1 TX9042 PSC Planned Preventative Maintenance

6.1.1 Overview

To keep your TX9042 PSC in the best possible condition and fully working, Trolex strongly recommends that you carry out regular planned preventative maintenance and keep records of the maintenance carried out.

The planned preventative maintenance for the TX9042 PSC consists of tasks carried out at regular intervals. The tasks are listed in the maintenance schedule below:

Equipment Name	Task Type	Task Number	Interval
TX9042 PSC	Check	6.1.2	6 months
TX9042 PSC Battery	Replace	6.1.3	5 years
TX9042 PSC - only to be carried out if the TX9042 is installed in a SIL rated system.	Proof Test	6.1.4	3 months OR 12 months

6.1.2 TX9042 PSC - Physical Check

Checkpoint

This maintenance task CAN be carried out underground.

1. Check the TX9042 PSC enclosure is securely attached. If the enclosure is not securely attached, resecure as necessary.

2. Check the TX9042 PSC enclosure for cracks, penetration, water ingress, signs of having been struck or other damage. Repair or replace the enclosure as necessary.
3. Check that the TX9042 PSC is securely attached to its enclosure. If the TX9042 PSC is not securely attached, resecure as necessary.
4. Check the exterior of the TX9042 PSC for cracks, penetration, water ingress, signs of having been struck or other damage.
5. Check the LCD screen is clear, can be easily read and is free from damage or defect.
6. Check the LCD screen shows no short circuit or open circuit conditions on any of the 8 channels.
7. Check that the Keypad L, R, U and D keys are free from damage or defect.
8. Check that the two terminal identification labels are securely attached, legible and free from damage or defect. Repair or replace the two labels as necessary.
9. Check all wires connected to the TX9042 PSC are secure within the terminals. Tighten any loose terminals as necessary.
10. If any part of the TX9042 PSC shows any signs of damage, defect, deformation or missing parts, immediately remove it from service and replace it with a working TX9042 PSC. Return the defective TX9042 PSC to your local Trolex service agent for repair and testing.
11. After the completion of all maintenance, update the maintenance records.

6.1.3 TX9042 PSC - Replace the battery

Checkpoint

This maintenance task CANNOT be carried out underground.

1. Remove the TX9042 PSC from service and replace it with a working TX9042 PSC.
2. Return the TX9042 PSC to your local Trolex service agent for battery replacement and testing.
3. After the completion of all maintenance, update the maintenance records.

6.1.4 TX9042 PSC - Proof Test

Checkpoint

This maintenance task CAN be carried out underground.

Checkpoint

A Proof Test must be carried out at regular intervals if the TX9042 PSC is being used in a SIL rated system. The interval of 3 months or 12 months depends upon the SIL rating and whether the safety function is defined as Low or High Demand. See Section 3 for further information.

1. Open the IP rated enclosure housing the TX9042 PSC.
2. Establish which input channels have a 4 to 20 mA or 0.4 to 2 V input AND are configured to de-energise an output channel relay, and which output channel relay it is. These are the input channels to be proof tested.

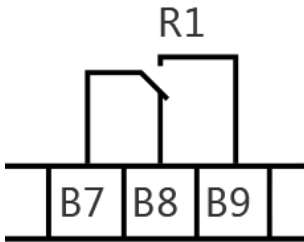

Relay shown de-energised

3. On one of the input channel(s) identified in the previous step, connect an Intrinsically Safe meter across the output channel relay terminals. See section 4.5 for details of relay terminal locations. Each relay has three terminals.

Checkpoint

Relay R1 - B7 common, B8 & B9

Relay R2 - B10 common, B11 & B12

Relay R3 - B13 common, B14 & B15

Relay R4 - B16 common, B17 & B18

4. The IS meter should be connected to the common terminal and the higher numbered terminal for the output channel relay being tested.
 - Relay R1 - B7 and B9
 - Relay R2 - B10 and B12
 - Relay R3 - B13 and B15
 - Relay R4 - B16 and B18
5. On the first input channel to be proof tested, apply a load or stimulus to the sensor or detector. The load or stimulus should be sufficient that it exceeds the programmed setpoint level for that input channel.

Checkpoint

How load or stimulus is applied to the sensor or detector, is the responsibility of the person responsible for SIL in the location where the TX9042 is installed. The determination of the correct load or stimulus, and how this is applied to the sensor or detector is beyond the scope of this User Manual.

6. As the load or stimulus exceeds the alarm threshold, observe that the reading on the IS meter fluctuates as the output channel relay de-energises.
7. If the IS meter reading fails to fluctuate, immediately remove the TX9042 PSC from service and replace it with a working TX9042 PSC. Return the defective TX9042 PSC to Trolex for repair and testing.
8. Remove the load or stimulus from the sensor or detector.
9. Reset the output channel relay.
10. Remove the IS meter connection from the higher numbered terminal and connect it to the middle numbered terminal of the output channel relay being tested.
 - Relay R1 - B8
 - Relay R2 - B11
 - Relay R3 - B14
 - Relay R4 - B17
11. Apply a load or stimulus to the sensor or detector. The load or stimulus should be sufficient that it exceeds the programmed setpoint level for that input channel.
12. As the load or stimulus exceeds the programmed setpoint level observe that the reading on the IS meter fluctuates as the output channel relay de-energises.
13. Remove the load or stimulus from the sensor or detector.
14. Reset the output channel relay.
15. Remove the IS meter connections from the output channel relay terminals.

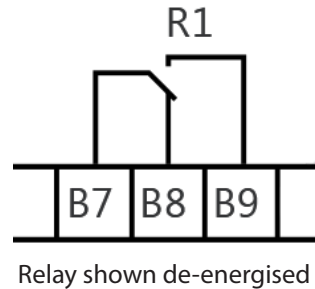

16. Repeat the test for each input channel that has a 4 to 20 mA or 0.4 to 2 V input AND is configured to operate an output channel relay.
17. If the IS meter reading fails to fluctuate for any of the output channel relay tests, immediately remove the TX9042 PSC from service and replace it with a working TX9042 PSC. Return the defective TX9042 PSC to Trolex for repair and testing.
18. After the completion of all maintenance, update the maintenance records.

6.2 TX9042 PSC - Repair

Should your TX9042 PSC become damaged and require repair, immediately remove it from service, replace it with a working TX9042 PSC and contact your local Trolex service agent to arrange repair.

Checkpoint

If your TX9042 PSC is used in a SIL rated system it can only be repaired by Trolex.

6.3 Maintenance Records

Implement a planned preventative maintenance process and keep good maintenance records.

Consult your local Trolex service agent or the Trolex Product Support Department: service@trolex.com for help in implementing a planned preventative maintenance process. The Maintenance Log gives an example of a typical maintenance record system.

7. Disposal

Part of the ethos of Trolex is sustainable design. TX9042 PSC contains materials that can be recovered, recycled and reused.

At the end of its useful life ensure that the TX9042 PSC is recycled in accordance with local laws and bylaws for the geographic area where it is located. The end of its useful life is to be determined by the owner/operator of the equipment and not Trolex.

Ensure that the TX9042 PSC is recycled by a licenced waste handling organisation with the appropriate licences for handling electronic waste in the geographic area where the TX9042 PSC is located.

Checkpoint

Consult your local Trolex service agent or the Trolex Product Support Department if you require assistance:
service@trolex.com

Disclaimers

The information provided in this document contains general descriptions and technical characteristics of the performance of the product. It is not intended as a substitute for and is not to be used for determining suitability or reliability of this product for specific user applications. It is the duty of any user or installer to perform the appropriate and complete risk analysis, evaluation and testing of the products with respect to the relevant specific application or use. Trolex shall not be responsible or liable for misuse of the information contained herein. If you have any suggestions for improvements or amendments, or find errors in this publication, please notify us at marketing@trolex.com.

No part of this document may be reproduced in any form or by any means, electronic or mechanical, including photocopying, without express written permission of Trolex.

All pertinent state, regional, and local safety regulations must be observed when installing and using this product. For reasons of safety and to help ensure compliance with documented system data, only Trolex or its affiliates should perform repairs to components.

When devices are used for applications with technical safety requirements, the relevant instructions must be followed.

Trademarks

© 2014 Trolex® Limited.

Trolex is a registered trademark of Trolex Limited. The use of all trademarks in this document is acknowledged.

Document History

Issue 01	15 October 2014	Original publication of this document
Issue 02	03 June 2015	Second publication of this document
Revision A	04 October 2023	Third publication of this document

Contact Details

Trolex Ltd, Newby Road, Hazel Grove, Stockport, Cheshire, SK7 5DY, UK
+44 (0) 161 483 1435 sales@trolex.com