



TX6831 Data Sheet & User Manual

Audio/Visual Alarm

Combined audible and visual alarm, for use with monitoring systems in hazardous areas

Environments: Mining • Tunnelling • Machine monitoring

Features

- High intensity LED all-round visual alert with 85 dB audible sounder
- Compact and shock resistant moulded polymer housing with cable termination facilities
- Rugged design with IP65 ingress protection
- Confidence alert signal at 15 second intervals
- Choice of LED colours
- Configurable input signal: 4 to 20 mA analogue, 0.4 to 2 V analogue and contact state
- Configurable alarm setpoint can be set for RISING or FALLING input signal mode
- Certified intrinsically safe for use in Group I hazardous areas



TX6831
with terminal box



Functional Overview

Supplied in a compact and strong moulded polycarbonate housing, this high-intensity LED visual alarm has an optional 85 dB audible sounder.

The alarm can be fitted directly to many Trolex sensor/transmitters using the terminals inside the sensor housing, or can be supplied fitted directly to a junction box.

Choice of Analogue or Contact State input signal compatibility, with user-adjustable alarm trigger setpoints, selectable for Rising / Falling input modes.

Certified intrinsically safe for use in Group I hazardous areas, for use with sensors and monitoring systems in hazardous areas. Versions available with visual alarm only.



TX6831
with flexible lead for OEM applications



Technical Details

Light source:	High intensity LEDs
Input signal:	<ul style="list-style-type: none">• Contact state - OPEN or CLOSE for alarm• Analogue signals with adjustable setpoint, configurable for RISING or FALLING signal mode
Alarm indication:	<ul style="list-style-type: none">• Audible sounder: 85 dB @ 1 m (12 V dc)• Confidence alert flash at 15 second intervals• Input signal out-of-limits: Alternating visual/audible pulses
Flash Patterns:	<ul style="list-style-type: none">• Standard (15 s intervals)• Solid (no confidence beep)• 1 s 50 % Duty A+V Sync• 1.5 s 50 % Duty A+V Sync• 4 s 50 % Duty A+V Sync• Solid
Connections:	4 mm clamp terminals or 300 mm flexible lead for OEM applications
Setpoint hysteresis:	5 % of setpoint
Housing material:	Electrically dissipative polymer
Protection classification:	IP65 (sounder to IP54)
Nett weight:	120 g 480 g with terminal box

Electrical Details

Supply voltage:	7.7 V to 16.5 V dc from an intrinsically safe source
Power consumption:	15 mA in standby condition 75 mA peak during LED flash
Analogue input signal:	4 to 20 mA or 0.4 to 2 V

Dimensions

TX6831 with terminal box P5459.28

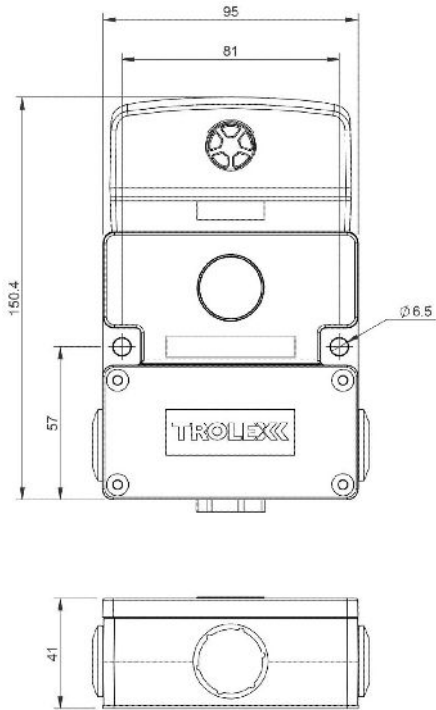

TX6831 with flexible lead for OEM applications

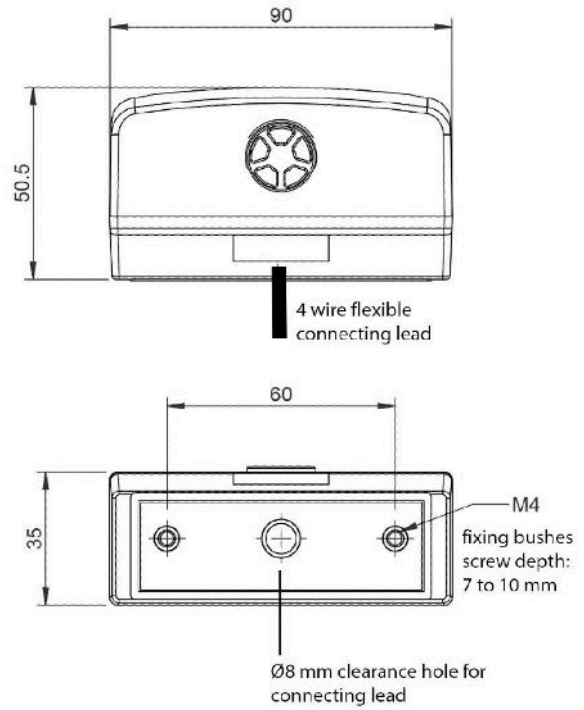

TX6831 with terminal box P5459.32

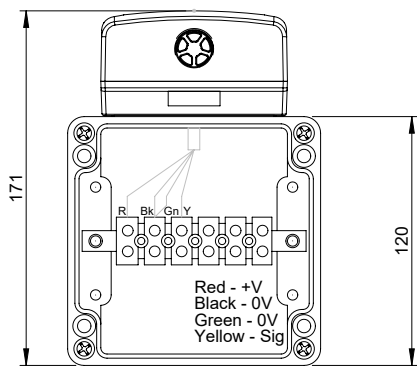

Enclosure Reinforced Polyester, IP65

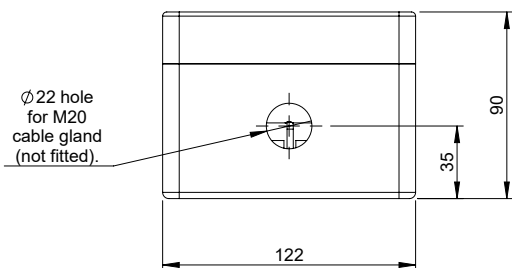

TX6831 with terminal box P5459.43

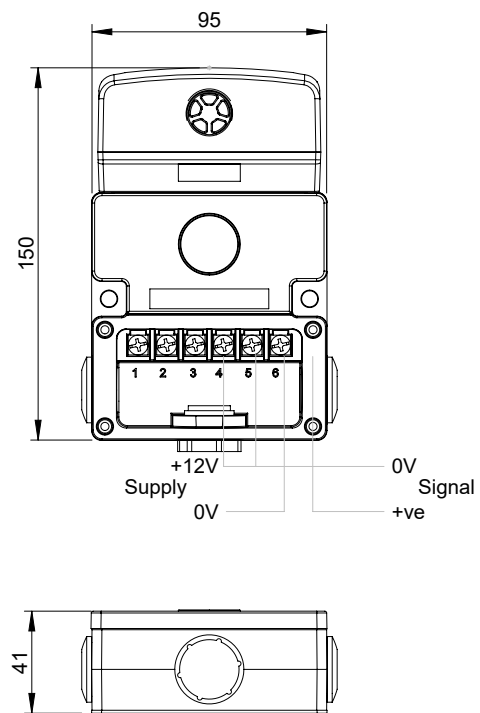



TX6831 Data Sheet & User Manual

TX6831 with terminal box P5459.45

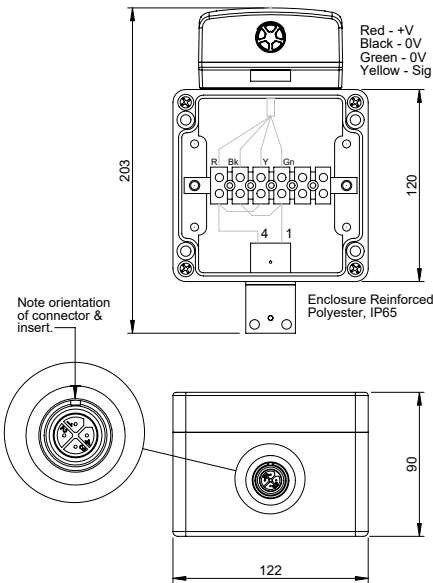

Setup

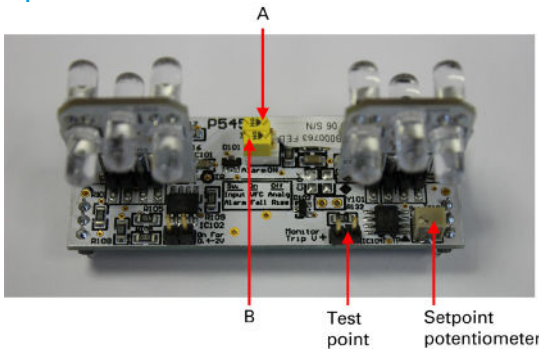

Type of input signal - selector switch A				
A	4 to 20 mA analogue input	0.4 to 2 V analogue input	5 V state input	contact state input
	OFF	OFF	ON	ON

Alarm setpoint mode - selector switch B			
B	Analogue input	Analogue input	Voltage free contacts
	Alarm on rising signal	Alarm on high level	Alarm on contacts closing
	OFF	OFF	OFF
	Alarm on falling signal	Alarm on low level	Alarm on contacts opening
	ON	ON	ON

Adjusting the setpoint

The alarm setpoint can be configured by adjusting the Setpoint potentiometer. By default the audio/visual alarm is configured with an alarm level of 50% of full scale.

Connect an approved test instrument configured to measure 0 to 2 V to the Test Point. Power up the audio visual alarm, refer to the Connection diagrams on page 5 if necessary.

The output voltage from the test point is linear and proportional to the alarm level, 0.4 V equals 0% of full scale and 2.0 V equals 100% of full scale. Each voltage increase of 0.016 V equals an increase of 1% of full scale. By default the audio/visual alarm is configured with an alarm level of 50% of full scale, i.e. 1.2 V.

Turning the potentiometer clockwise increases the alarm setpoint or turning it anti-clockwise decreases the alarm setpoint. Use a small screwdriver turn the potentiometer and set the alarm setpoint to the desired level.



Connections

Unit Connections

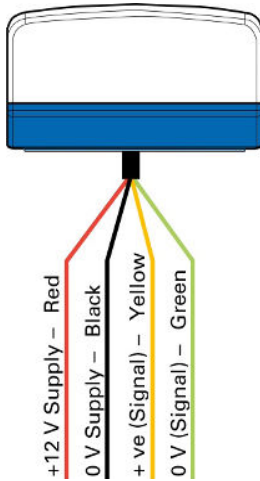

Connecting to a 4 to 20 mA signal loop

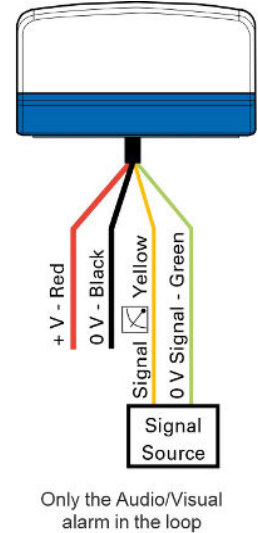
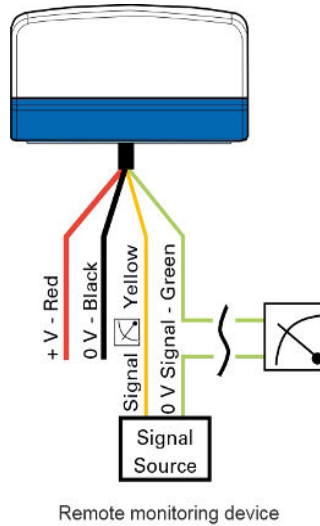

Connecting to a 0.4 to 2 V signal source

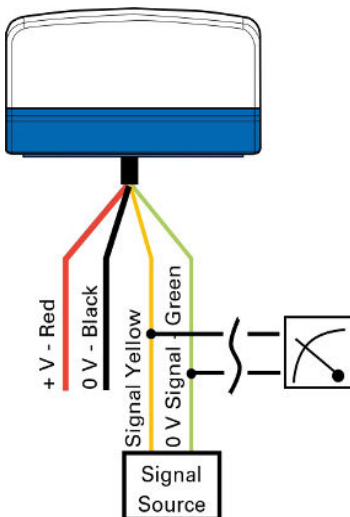

Connecting to a volt free input contact

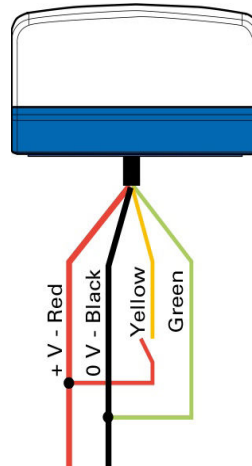

Connecting to a 5 V state input

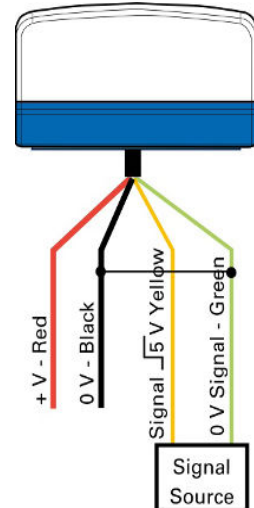

The TX6831 Audio/Visual Alarm must only be interconnected with approved power supplies, signal sources and monitoring equipment when used in hazardous areas.



TX6831 Data Sheet & User Manual

Order Reference

TX reference	•	Certification	•	Input	•	LED colour	•	Sounder	•	Flash pattern	•	Terminal Box
TX6831	•	05	•	12	•	91	•	901	•	20	•	01
example:		MASC Grp I		4 - 20 Ma		Red		with sounder		Solid		P5459.28

Certification	
General Purpose	00
MASC Grp I	05
ANZEx Grp I	10
EAC Grp I	14
ATEX/IECEx Grp I	19
UKRAINE Grp I	24
Input	
0.4 - 2.0 V	11
4 - 20 mA	12
Contact	14

Sounder	
With sounder	901
No sounder	902
LED colour	
Red	91
Yellow	92
Green	93
Blue	94
Amber	95
White	96

Flash Pattern	
15 s (standard)	15
Solid (No confidence Beep)	16
1 s 50 % Duty A+V Sync	17
1.5 s 50 % Duty A+V Sync	18
4 s 50 % Duty A+V Sync	19
Solid	20
Terminal Box	
No terminal box (with flexible lead)	00
P5459.28 (standard version)	01
P5459.32	02
P5459.43	03
P5459.45	04

Certification & Conformity

1. European Union (ATEX) and International (IECEX) certification

	ATEX (European Union) certification for use in underground mines (Group I). Complies with ATEX Directive 2014/34/EU.
	Standards: EN IEC 60079-0:2018 EN 60079-11:2012

	IECEX (International) certification for use in underground mines (Group I).
	Standards: IEC 60079-0:2017 IEC 60079-11:2011

Product Code:	Ex Certificate Number:	Ex Certification Code:
TX6831.19(.xx...) Audio/Visual Alarm	Sira 99ATEX2152X IECEX SIR 15.0059X	I M1 Ex ia I Ma Ta = -20°C to +60°C

The following Special conditions for Use apply to the certificates listed above:

- Under normal or fault conditions, the internal temperature of this equipment may rise above 150°C; therefore, care shall be taken when the enclosure is opened to ensure that no dust enters the equipment.
- The antistatic coating can be adversely affected by contact with acid or damage to the lens. Suitable precautions shall be taken to avoid such instances and the lens shall be inspected periodically for any damage.

Intrinsic safety parameters

Power input (Red and Black Wire)

U_i = 16.5 V C_i = 1.2 nF L_i = 0

Input signal (Yellow and Green Wire)

U_i = 16.5 V C_i = 0 L_i = 0

Monitor trip voltage (Test point)

U_i = 16.5 V C_i = 0 L_i = 0



2. Australia (ANZEx)

ANZEx	ANZEx certification for use in underground mines (Group I) in Australia.
--------------	--

Product Code:	Ex Certificate Number:	Ex Certification Code:
TX6831.10(.xx...) Audio/Visual Alarm	ANZEx 12.3005X	Ex ia I Ta = -20°C to +60°C

The following Special conditions for Use apply to the certificates listed above:

It is a condition of safe use that the following entity parameters for the terminals shall be taken into account during installation:

	Input parameters	
	Power supply terminal	Other terminals
Maximum Supply Voltage Ui	16.5 V	16.5 V
Maximum Input Capacitance Ci	3.18 uF	0
Maximum Input Inductance Li	0	0

3. South Africa (MASC IA)

	MASC IA certification for use in underground mines (Group I) in South Africa.
--	---

Product Code:	Ex Certificate Number:	Ex Certification Code:
TX6831.05(.xx...) Audio/Visual Alarm	MASC M/11-222X Sira 99ATEX2152X	I M1 Ex ia I Ma Ta = -20°C to +60°C

The following Special conditions for Use apply to the certificates listed above:

- Under normal or fault conditions, the internal temperature of this equipment may rise above 150°C; therefore, care shall be taken when the enclosure is opened to ensure that no dust enters the equipment.
- The antistatic coating can be adversely affected by contact with acid or damage to the lens. Suitable precautions shall be taken to avoid such instances and the lens shall be inspected periodically for any damage.

Intrinsic safety parameters

Power input (Red and Black Wire)

Ui = 16.5 V Ci = 1.2 nF Li = 0

Input signal (Yellow and Green Wire)

Ui = 16.5 V Ci = 0 Li = 0

Monitor trip voltage (Test point)

Ui = 16.5 V Ci = 0 Li = 0

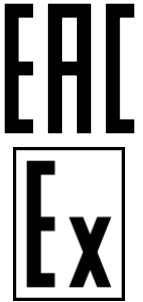

4. Eurasian Customs Union (EAC)

	<p>EAC certification for use in underground mines in Eurasian Customs Union (including Russia).</p>
---	---

Product Code:	Ex Certificate Number:	Ex Certification Code:
<p>TX6831.14(.xx...) Audio/Visual Alarm</p>	<p>RU C-GB.HB66.B.000152/23</p>	<p>PO Ex ia I Ma X Ta = -20°C to +60°C</p>

Special conditions for Use and Intrinsic safety parameters

Please refer to the certificate listed above for full details.

Installation of equipment

The installation of the product must only be carried out by competent personnel. Each installation needs to be considered with reference to the local safety regulations and authorities. Refer to the following standards for additional guidance:

- IEC/EN 60079-14
- IEC/EN 60079-25

Refer to the Certification Section of this User Manual and to the relevant certificates for any installation parameters and special conditions of safe use.

Commissioning / verification tests prior to first use.

Prior to commissioning and first use, the product shall be inspected for any visible damages and integrity of the enclosure. Never use the product that has damaged housing in hazardous locations.

Maintenance

The maintenance of the product must only be carried out by competent personnel. Maintenance shall be considered with reference to the local safety regulations and authorities. Refer to the following standards for additional guidance:

- IEC/EN 60079-17

It is recommended to periodically check the condition of the product.

The product shall only be serviced and repaired by Trolex Ltd. or a local Trolex service agent approved by Trolex Ltd in order to maintain the explosion protection of the product.