



TX5921 • TX5922 • TX5923  
Vortex Air Flow Sensor



**TROLEX** <<

# User Manual

## TX5921-2-3 Vortex Air Flow Sensor

### Contents

1.	Product Overview	3	Disclaimers	31
1.1	Operating Features	4	Trademarks	31
1.2	Application	4	Document History	31
1.3	Product Options	5	Contact Details	31
1.4	Dimensions	8		
1.4.1	TX5921 Rear Projecting Sensor	8		
1.4.2	TX5922 Side Projecting Sensor	10		
1.4.3	TX5923 Remote Mounted Sensor	11		
1.5	Technical Information	12		
1.6	Electrical Details	14		
1.7	Connections	15		
2.	Certification & Conformity	17		
3.	Installation	20		
3.1	Tools and Test Equipment Required	20		
3.2	Siting Recommendations	20		
3.2.1	Fitting in Pipes and Ducts	20		
3.2.2	Fitting in Roadways and tunnels	22		
3.3	Orientation of the Housing	23		
4.	Setup and Calibration	23		
4.1	Controls and Indicators	23		
4.2	Software Menus	24		
4.2.1	Setup	26		
4.3	Output Signal Check	28		
4.3.1	Sensing Probe Function Test	28		
4.3.2	Sensing Probe Clean	28		
4.4	Disposal	29		
4.5	Maintenance Records	29		
4.6	Maintenance Log	30		

## 1. Product Overview

---

Vortex air flow sensor with rear projecting sensing probe suitable for duct monitoring

TX5921

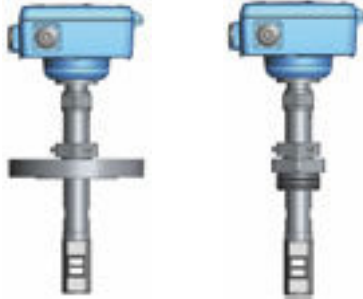

Vortex air flow sensor with side projecting sensing probe for open flow monitoring in tunnels, roadways and process systems.

TX5922



Vortex air flow sensor with remote mounted sensor. For use where fitting space is limited or is difficult to access.

TX5923



## 1.1 Operating Features

- High stability air flow monitoring
- Vortex monitoring principle with no moving components
- Output signal linearly proportional to flow velocity
- Integral LCD screen with large easy to read characters and back light illumination
- Easily programmable function and display configuration
- Choice of output signals:
  - 0.4 to 2 V
  - 4 to 20 mA
- Rangeable flow velocity from 0.5 m/sec to 30 m/sec

## 1.2 Application

Fixed point air flow velocity measurement in pipes, ducts and open roadways.

Ventilation, cooling systems and process condition monitoring in heavy duty industrial applications and hazardous areas. Output data linearly proportional to air flow velocity.

## 1.3 Product Options

### Vortex Air Flow Sensor

Sensor Configuration	Product Code
Rear projecting sensor	TX5921
Side projecting sensor	TX5922
Remote sensor	TX5923

Certification	Option Code
General Purpose	.00
ATEX Grp I	.35.01
MASC Grp I	.05
ANZEx Grp I	.10
EAC Grp I	.14
CIMFR Grp I	.21
ATEX Grp II	.35.02
MASC Grp II	.16
ANZEx Grp II	.11
EAC Grp II	.15
Ukraine Grp I	.24

Output Signal	Option Code
0.4 - 2 V	.11 Grp I Only
4 - 20 mA	.12

Process Fitting	Option Code
None	.00
50 mm ANSI flange	.21
1 1/2 " BSP bush	.22

Probe Length	Option Code
--------------	-------------

165 mm (standard)	.00
500 mm	.02
1000 mm	.03
1800 mm	.04

Velocity Range	Option Code
5 m/s	.01
10 m/s	.02
15 m/s	.03
20 m/s	.04
25 m/s	.05
30 m/s	.06

Cable Length (TX5923 Only)	Option Code
0 m	.00
1 m	.01
2 m (standard)	.02
3 m	.03
4 m	.04
5 m	.05
6 m	.06
7 m	.07
8 m	.08
9 m	.09
10 m (max)	.10

### Vortex Air Flow Sensor - Replacement Sensing Head Only

Sensor Configuration		Product Code
Rear projecting sensor	head only	P5431.6000.01
Side projecting sensor	head only	P5431.6000.02
Remote sensor	head only	P5431.6000.03

Process Fitting	Option Code
None	.00
50 mm ANSI flange	.21
1 1/2 " BSP bush	.22

Probe Length	Option Code
165 mm (standard)	.00
500 mm	.02
1000 mm	.03
1800 mm	.04

Cable Length	Option Code	
0 m	.00	P5431.6000.01/.02
1 m	.01	1m to 10m cable length P5431.6000.03 only
2 m (standard)	.02	
3 m	.03	
4 m	.04	
5 m	.05	
6 m	.06	
7 m	.07	
8 m	.08	
9 m	.09	
10 m (max)	.10	

## 1.4 Dimensions

### 1.4.1 TX5921 Rear Projecting Sensor

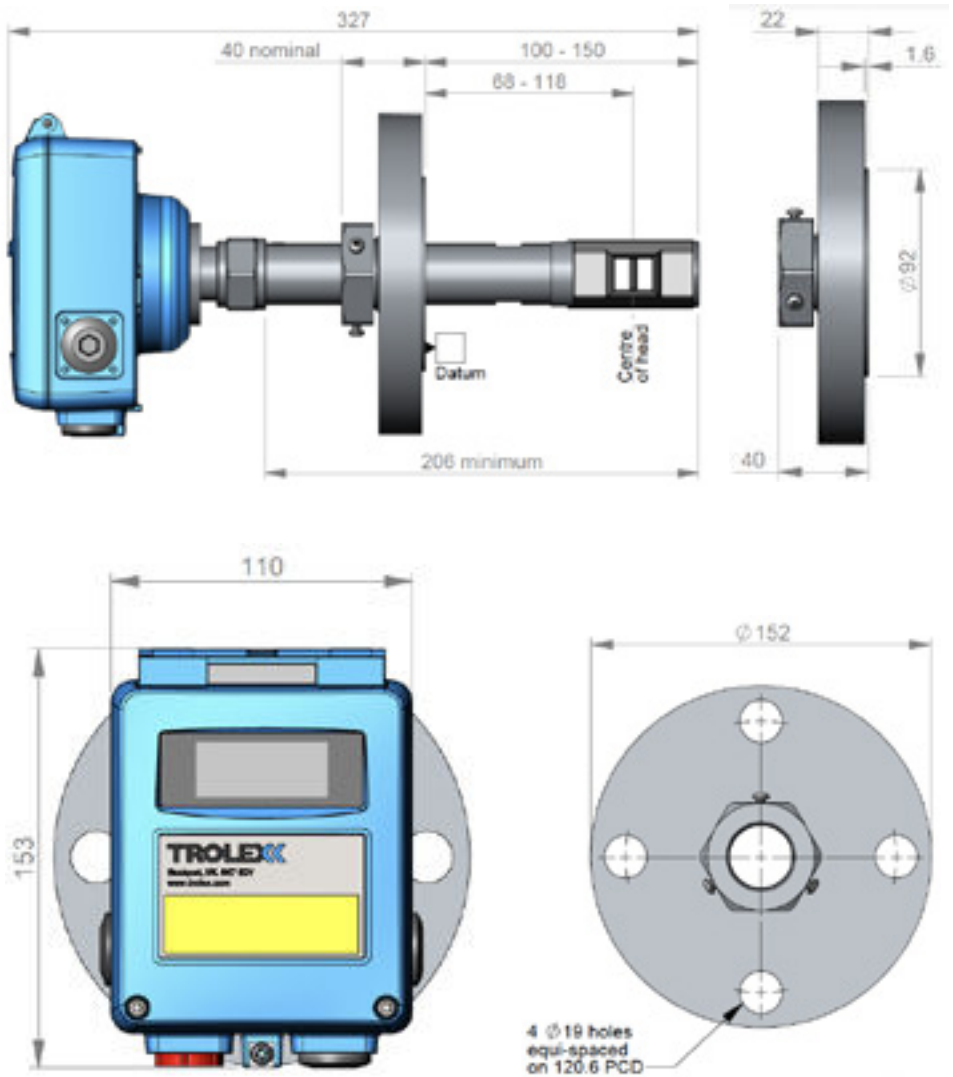

## TX5921 Rear Projecting Sensor

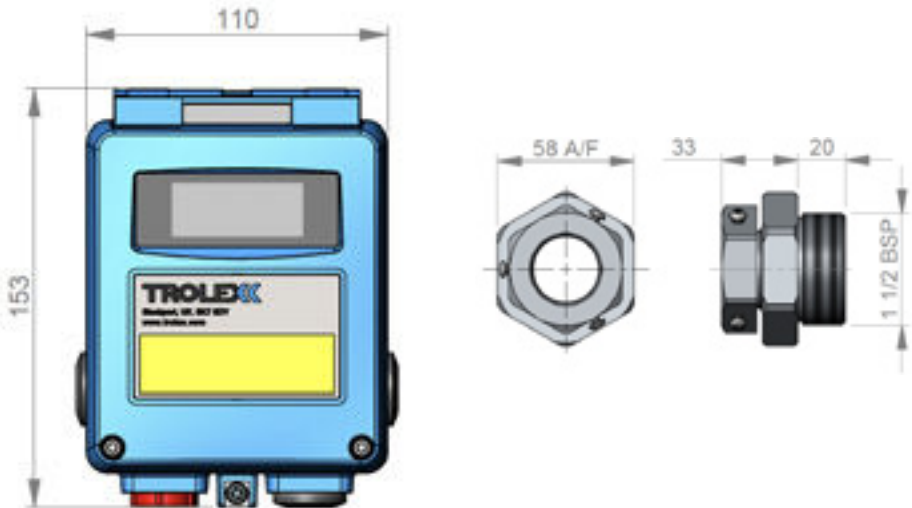
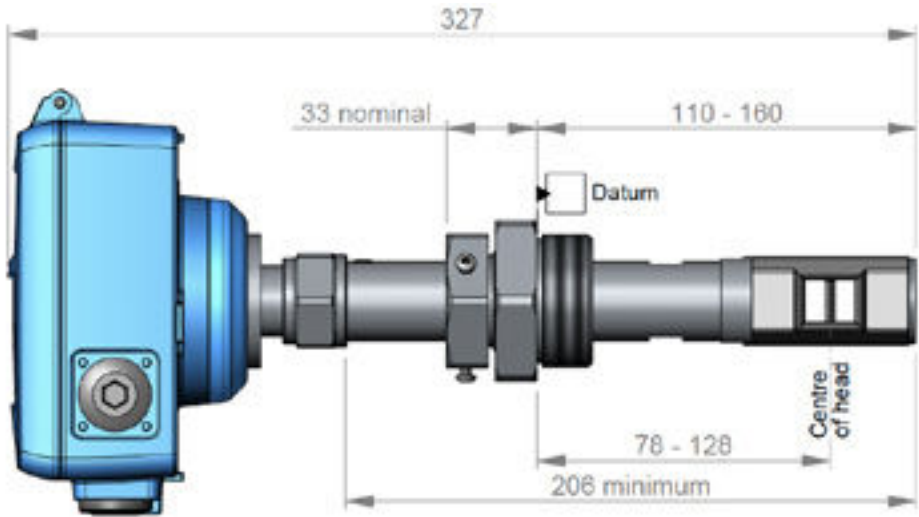

## 1.4.2 TX5922 Side Projecting Sensor

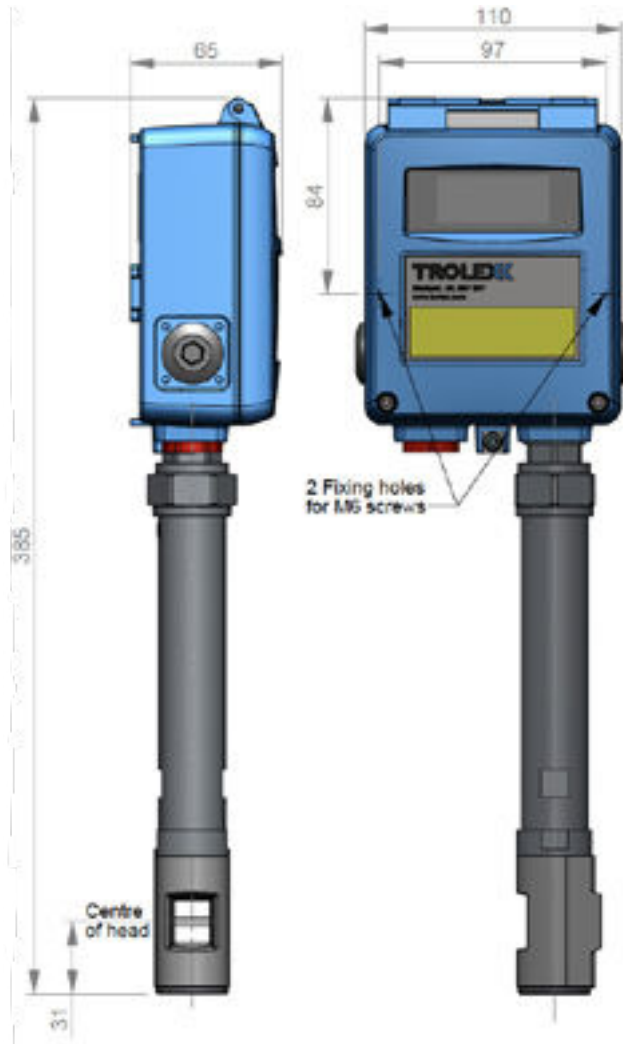

## 1.4.3 TX5923 Remote Mounted Sensor

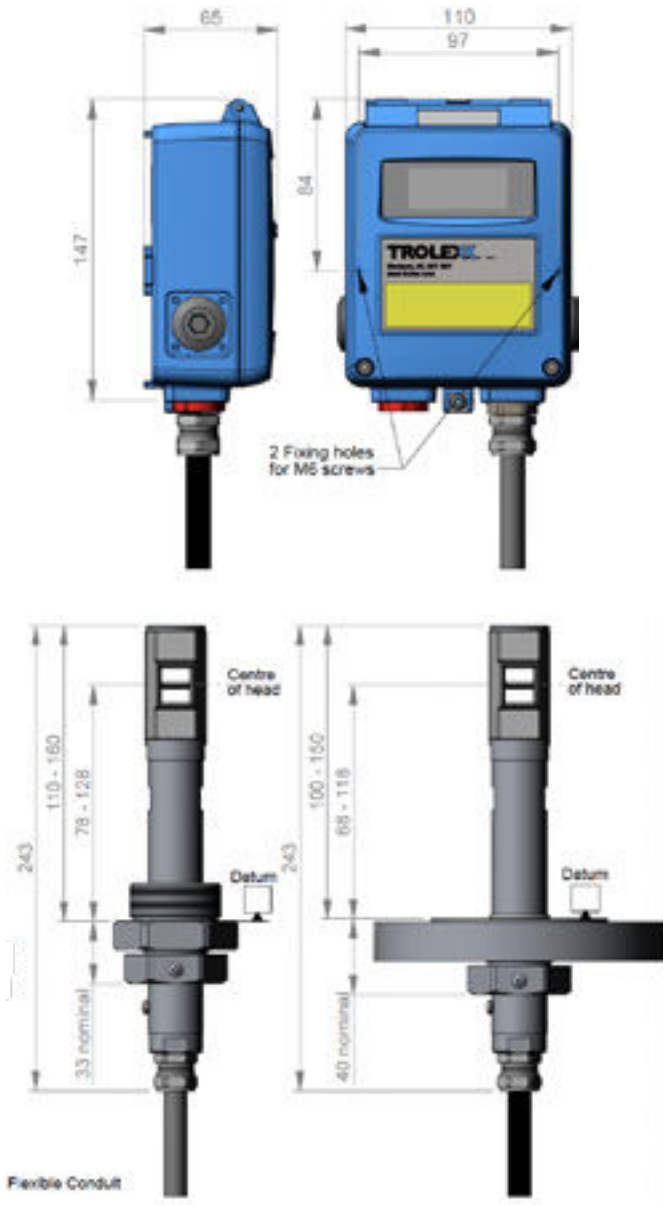

## 1.5 Technical Information

Flow measuring range	Rangeable from 0.5 to 5 m/s up to 0.5 to 30 m/s
Accuracy	+/- 2% within 12.5° rotation of flow axis
Linearity	+/- 1%
Ambient temperature limits	-15 °C to +50 °C
Sensor temperature limit	-20 °C to +150 °C
Humidity	0 to 95% non-condensing
Protection classification	Dust and waterproof to IP65
Process media	Gas, air, steam or saturated vapour
Housing material	Electrically dissipative polymer
Sensor material	Stainless steel - grade 316
Flexible cable (remote sensor)	PVC coated armoured flexible conduit
Maximum static pressure	20 bar
Process fittings	<ul style="list-style-type: none"> <li>• 1 1/2" BSP mounting bush</li> <li>• 50 mm ANSI mounting flange</li> </ul>
Cable entry	<ul style="list-style-type: none"> <li>• Rear projecting sensing probe - 2 x M20</li> <li>• Side projecting sensing probe - 1 x M20</li> <li>• Remote mounted sensing probe - 1 x 2M20</li> </ul>
Nett weight	<ul style="list-style-type: none"> <li>• Rear projecting sensing probe - 1.5 kg</li> <li>• Side projecting sensing probe - 1.5 kg</li> <li>• Remote mounted sensing probe - 2.5 kg</li> </ul>
Information display	128 x 64 dot graphic backlit LCD screen
Vibration limits	<ul style="list-style-type: none"> <li>• 10 to 30 Hz - 1.00 mm total excursion</li> <li>• 31 to 150 Hz - 19.6 m/s<sup>2</sup> acceleration peak</li> </ul>
Impact limits	20 joules (housing)
Output Signals	<ul style="list-style-type: none"> <li>• 0.4 to 2 V</li> <li>• 4 to 20 mA</li> </ul>

Programmable Information

- zero & span
- signal offset
- volumetric calculations
- engineering units
- turndown & damping
- display contrast & suppression
- fault mode & signal clamp

## 1.6 Electrical Details

General Purpose Applications	
Output signal:	4 to 20mA
Max load:	600 $\Omega$ at 24 V dc
Power supply:	10 to 30 V dc
Max current:	40 mA

Group I applications (when powered from approved apparatus)		
Output signal:	4 to 20 mA	0.4 - 2 V dc
Max load:	300 $\Omega$ at 12 V dc	10 k Ohms at 12 V dc
Power supply:	6.5 to 16.5 V d	6.5 to 16.5 V dc
Max current:	15 mA	15 mA

Group II applications (when powered from approved safety barriers)	
Output signal:	4 to 20 mA
Max load:	600 $\Omega$ at 24 V dc
Power supply:	10 to 30 V dc
Max current:	40 mA

## 1.7 Connections

### Integral sensor

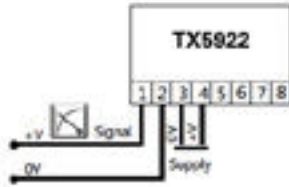

### Remote sensor

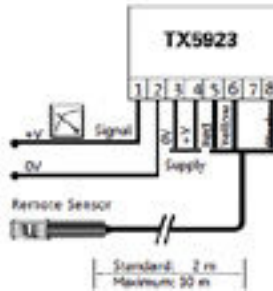

### 4 to 20 ma output signal

The output signal is a standard 4 to 20 mA current regulated signal loop.

The sensor also requires a separate power supply feed and can be connected in either the 3 wire or 4 wire mode.

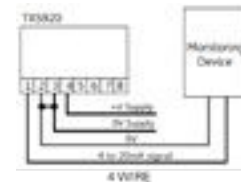
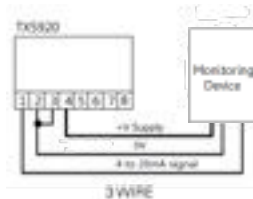

### 0.4 to 2 V output signal

A low impedance output requiring a separate power supply.

The 3 wire connection mode works well up to about 100 metres.

Use the 4 wire mode for longer distances or increase the size of the cable cores.

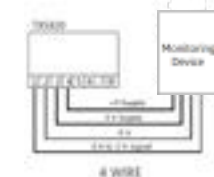
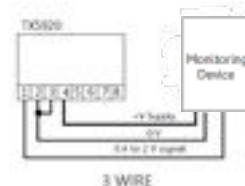

### Group II hazardous area

Sensor versions with 4 - 20 mA output are certified intrinsically safe for use in Group II hazardous areas, Zone 0, Zone 1, and Zone 2 when used in conjunction with approved safety barriers.

Only the sensor may be mounted in the hazardous area.

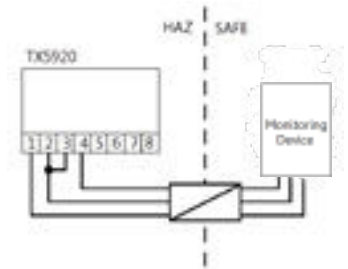

### Group I hazardous areas

All versions of the sensor are certified intrinsically safe for use in Group I hazardous areas (Mining) when used with approved apparatus.

The complete systems, both sensor and monitoring device can be mounted in the hazardous area.

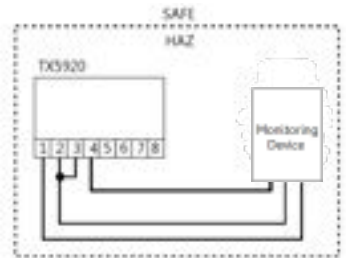

## 2. Certification & Conformity

### 1. European Union

	<p>ATEX (European Union) certification for use in underground mines (Group I) and Industrial (Group II) locations.</p> <p>Complies with ATEX Directive 2014/34/EU.</p> <p>Standards: EN IEC 60079-0:2018 EN IEC 60079-11:2024</p>
---	---

Product Code:	Ex Certificate Number:	Ex Certification Code:
TX5921.35.01(.xx...) TX5922.35.01(.xx...) TX5923.35.01(.xx...)	CML 26ATEX2018X	I M1 Ex ia I Ma Ta = -20°C to +60°C
TX5921.35.02(.xx...) TX5922.35.02(.xx...) TX5923.35.02(.xx...)		II 1G Ex ia IIC T4 Ga Ta = -20°C to +60°C

### Intrinsic safety parameters

For intrinsic safety parameters associated with certificates listed above, please refer to individual certificates. Copies of certificates are available on [www.troxel.com](http://www.troxel.com). The following intrinsic safety parameters apply the equipment listed above.

Version	T3/T4 (supply)	T1/T2 (signal out) See notes 1 - 3
Group I 4 - 20 mA version	Ui = 16.5 V Ci = 4 nF Li = 0	Ui = 16.5 V Pi = 1.72 W Ci = 15 nF Li = 0 Uo = 16.5 V Io = 220 mA Po = 0.91 W Co = 11.9 uF Lo = 2.6 mH
Group I 0.4 - 2 V version	Ui = 16.5 V Ci = 4 nF Li = 0	Ui = 16.5 V Pi = 1.72 W Ci = 15 nF Li = 0 Uo = 16.5 V Io = 41 mA Po = 0.17 W Co = 11.9 uF Lo = 2.6 mH

Version	T1/T2/T3/T4 (total inputs to 'supply' and 'signal out')
Group II 4 - 20 mA version	Ui = 28 V Ii = 120 mA Pi = 0.84 W Ci = 18.3 nF Li = 0

**Note 1:** In some applications, T1 and T2 are inputs, in which case these output parameters are not relevant.

**Note 2:** For Group I builds, the connections to terminals T1/T2 and T3/T4 shall be from the same power supply.

The user should note that the power to terminals T1/T2 must be limited to 1.72 W via a supply with a minimum

source resistance of 40 Ohm. There is no specific power limitation to terminals T3/T4, so terminals T1/T2 and T3/T4 should be regarded as separate intrinsically safe circuits.

**Note 3:** The user should refer to the parameters of the equipment connected to terminals T1/T2 and compare these to the parameters listed in the table. The more onerous set of parameters should be used.

**Note 4:** Terminals T5, T6 and T8 are connections to the Vortex Head which may be integral with the main part of the apparatus (TX5921 and TX5922) or connected by a cable not exceeding 10 m in length (TX5923). T7 is not connected.

### The following Special conditions for Use apply to the certificates listed above:

- i. The only sensor that may be used with the TX5923 (remote sensor head version) is that supplied by Trolex. The maximum length of cable allowed is 10 m.
- ii. The plastic enclosure and the polycarbonate window are non-conducting and may generate an ignition capable level of static under certain extreme conditions. The user should ensure that the equipment is not installed in a location where it may be subjected to external conditions (such as high-pressure steam) which might cause a build-up of static on non-conducting surfaces. Additionally, cleaning of the equipment should be done only with a damp cloth.

## 2. Australia

<b>ANZEx</b>	ANZEx certification for use in underground mines (Group I) and Industrial (Group II) locations in Australia.
--------------	--

Product Code:	Ex Certificate Number:	Ex Certification Code:
TX5921.10(.xx...) TX5922.10(.xx...) TX5923.10(.xx...)	ANZEx 12.3003X	Ex ia I Ta = -20°C to +60°C
TX5921.11(.xx...) TX5922.11(.xx...) TX5923.11(.xx...)		Ex ia IIC T4 Ta = -20°C to +60°C

### Intrinsic safety parameters

For intrinsic safety parameters associated with certificates listed above, please refer to individual certificates. Copies of certificates are available on [www.trolex.com](http://www.trolex.com). The following intrinsic safety parameters apply the equipment listed above.

Version	T3/T4 (supply)	T1/T2 (signal out) See notes 1 - 4
Group I 4 - 20 mA version	U <sub>i</sub> = 16.5 V C <sub>i</sub> = 4 nF L <sub>i</sub> = 0	U <sub>i</sub> = 16.5 V P <sub>i</sub> = 1.72 W (see Note 2) C <sub>i</sub> = 15 nF L <sub>i</sub> = 0 U <sub>o</sub> = 16.5 V I <sub>o</sub> = 223 mA P <sub>o</sub> = 0.921 W C <sub>o</sub> = 7 uF L <sub>o</sub> = 0.6 mH
Group I 0.4 - 2 V version	U <sub>i</sub> = 16.5 V C <sub>i</sub> = 4 nF L <sub>i</sub> = 0	U <sub>i</sub> = 16.5 V P <sub>i</sub> = 1.72 W (see Note 2) C <sub>i</sub> = 15 nF L <sub>i</sub> = 0 U <sub>o</sub> = 16.5 V I <sub>o</sub> = 41 mA P <sub>o</sub> = 0.17 W C <sub>o</sub> = 7 uF L <sub>o</sub> = 0.6 mH

Group I 5-15 Hz version	U <sub>i</sub> = 16.5 V C <sub>i</sub> = 4 nF L <sub>i</sub> = 0	U <sub>i</sub> = 16.5 V P <sub>i</sub> = 1.72 W (see Note 2) C <sub>i</sub> = 0 L <sub>i</sub> = 0 U <sub>o</sub> = 0
----------------------------	--	---

Version	T1/T2/T3/T4
Group II 4 – 20 mA version	U <sub>i</sub> = 28 V I <sub>i</sub> = 120 mA P <sub>i</sub> = 0.84 W R <sub>min</sub> = 233 Ohm (see Note 5) C <sub>i</sub> = 18.3 nF L <sub>i</sub> = 0

**Note 1:** In some applications, T1 and T2 are inputs, in which case these output parameters are not relevant.

**Note 2:** For Group I versions, the connections to terminals T1/T2 and T3/T4 shall be from the same power supply. The user should note that the power to terminals T1/T2 must be limited to 1.72W via a supply with a minimum source resistance of 40 Ohm. There is no specific power limitation to terminals T3/T4, so terminals T1/T2 and T3/T4 should be regarded as separate intrinsically safe circuits.

**Note 3:** Terminals T5, T6 and T8 are connections to the sensor head which may be integral with the main part of the apparatus (TX5921 and TX5922) or connected by a cable, not exceeding 10 m in length (TX5923) with cable inductance and capacitance of not more than 15uH and 15nF. T7 is not connected.

**Note 4:** The installer should refer to the parameters of the equipment connected to terminals T1/T2 and compare these to the parameters listed in the table.

**Note 5:** The user should note that the current and power to these terminals must be limited via a supply with a minimum source resistance of 233 Ohm.

**The following Special conditions for Use apply to the certificates listed above:**

- i. The apparatus shall only be cleaned with a damp cloth.

### 3. South Africa

	<p>MASC (IA) certification for use in underground mines (Group I) and industrial (Group II) locations in South Africa.</p>
---	--

Equipment / Product Code	Ex Certificate Number	Ex Certification Code
TX5921.05(.xx...) TX5922.05(.xx...) TX5923.05(.xx...)	MASC MS/25-8220X Sira 99ATEX2135X	I M1 Ex ia I Ma Ta = -20°C to +60°C
TX5921.16(.xx...) TX5922.16(.xx...) TX5923.16(.xx...)		II 1G Ex ia IIC Ga T4 Ta = -20°C to +60°C

For corresponding intrinsic safety parameters and special conditions for use, refer to ATEX certification above.

### 4. Eurasian Customs Union (EAC)

	<p>EAC certification for use in underground mines (Group I) and industrial (Group II) locations in Eurasian Customs Union (including Russia).</p>
---	---

Equipment / Product Code	Ex Certificate Number	Ex Certification Code
TX5921.14(.xx...) TX5922.14(.xx...) TX5923.14(.xx...)	RU C-GB.HB66.B.00012/23	PO Ex ia I Ma X Ta = -20°C to +60°C
TX5921.15(.xx...) TX5922.15(.xx...) TX5923.15(.xx...)		OEx ia IIC Ga T4 X Ta = -20°C to +60°C

## **Installation of equipment**

The installation of the product must only be carried out by competent personnel. Each installation needs to be considered with reference to the local safety regulations and authorities. Refer to the following standards for additional guidance:

- IEC/EN 60079-14
- IEC/EN 60079-25

Refer to the Certification Section of this User Manual and to the relevant certificates for any installation parameters and special conditions of safe use.

## **Commissioning / verification tests prior to first use.**

Prior to commissioning and first use, the product shall be inspected for any visible damages and integrity of the enclosure. Never use the product that has damaged housing in hazardous locations.

## **Maintenance**

The maintenance of the product must only be carried out by competent personnel. Maintenance shall be considered with reference to the local safety regulations and authorities. Refer to the following standards for additional guidance:

- IEC/EN 60079-17

It is recommended to periodically check the condition of the product.

The product shall only be serviced and repaired by Trolex Ltd. or a local Trolex service agent approved by Trolex Ltd in order to maintain the explosion protection of the product.

## 3. Installation

### 3.1 Tools and Test Equipment Required

No special tools are required:

- Metric spanner set
- Metric hexagon key set
- Standard electrical test meter

#### Checkpoint

Where the process cannot be interrupted to remove the Vortex from a pipeline, an isolating ball valve may be fitted to the process connection at the installation. This is also useful in installations that have a high level of contamination or moisture in the gas stream. Build up of debris or water vapour will cause deterioration of the output signal.

### 3.2 Siting Recommendations

#### 3.2.1 Fitting in Pipes and Ducts

To attain the best accuracy of response, select a position that is at least twenty pipe diameters down-stream from bends or obstructions, and approximately five pipe diameters from down-stream intrusions.

Similarly, the sensor should be mounted at least fifteen pipe diameters from a pipe reducer and fifty pipe diameters from valves.

If this is not possible then the installation of a standard flow straightener will improve performance.

Fit a corresponding threaded boss or flange

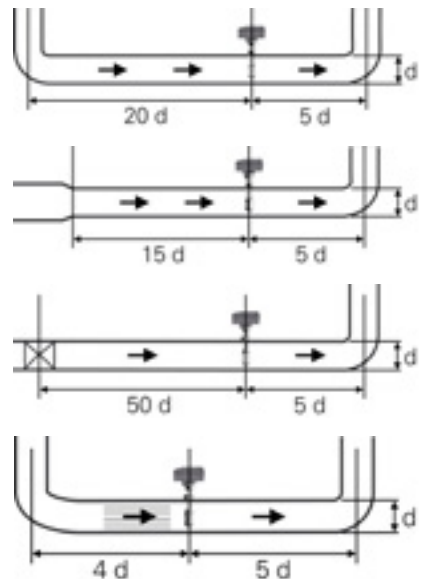



at the monitoring point and install the sensor, ensuring an airtight seal.

#### Checkpoint

High pressure versions, above 2 bar, will be supplied with a welded bush or flange and will require dedicated process fittings.

Release the clamping ring on the mounting bush or flange.

The centre of the flow path of the sensing head should be positioned as shown.

#### Checkpoint

Ensure that pressurised systems have been completely vented before installation or removal of the sensor.

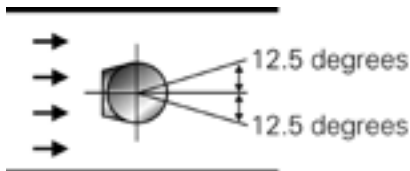
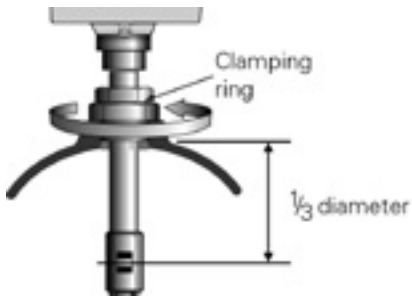

Position the sensing head with the smaller opening facing the flow, within a rotational deviation of no more than 12.5° from the axis of flow.

Tighten the clamping ring with moderate force.

Avoid fitting the sensor at low points in pipework structures to prevent the sensing head from being affected by large accumulations of moisture.



### 3.2.2 Fitting in Roadways and tunnels

To attain the best accuracy of response, select a position away from adjacent structures with a clearance of 200 mm.

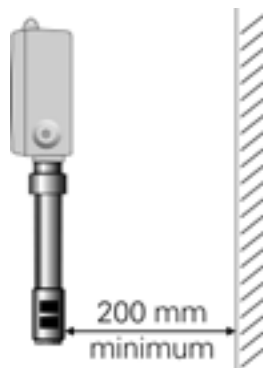

The version with a side projecting sensor can be mounted on to a suitable support using the mounting holes.



Alternatively use a standard mounting bush or flange for fitting to a suitable bracket.



### 3.3 Orientation of the Housing

The housing of the Vortex can be turned to any position about the axis of the sensing



probe and locked in position for the preferred mounting attitude or cable routing access.

Release the locking ring by turning anti-clockwise as far as it will go.

Rotate the sensing probe or the sensor housing to the desired position.

#### Checkpoint

Rotation is limited to approximately 300° so do not force the housing beyond the limit stops.

## 4. Setup and Calibration

### 4.1 Controls and Indicators

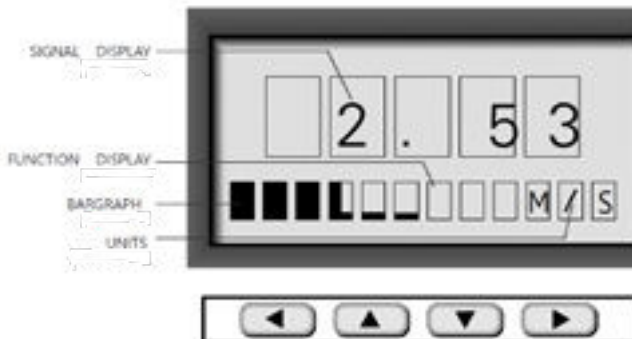

### 4.2 Software Menus

#### Switch On

The processor will initialize all the default settings or new data that has been previously programmed.

After two seconds the display will switch to the Main Display signal and Display magnitude mode.





The bar graph will also show an indication of signal level with a Signal Overrange alert marker.



#### Menu

Press  to enter

Press  or  to scroll the menu

Press  to confirm

A keycode will be requested if active



#### Messages

Entry saved: when new data is entered

Not saved: when data is not entered

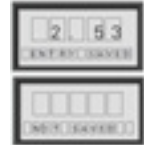

#### Exit

Press  to exit any position in the menu and step back to the Main Display.

#### Self-Test

The processor will perform a regular self-test routine to check all the systems elements.

Any malfunction will prompt a Fail message.



#### Keycode

Enter a four-digit keycode if security is active



Press  to traverse the digits

Press  to scroll the digit

Press  to confirm



**Set Keycode**

Enter a new security keycode.  
Set the status of the keycode:

Not active: -  
Active +



Press  $\blacktriangleleft$  to traverse the digits  
Press  $\blacktriangleright$  to scroll the digit  
Press  $\blacktriangleright$  to confirm



**Scaling**

The scaling values can be programmed

Press  $\blacktriangleleft$  or  $\blacktriangleright$  to select the function  
Press  $\blacktriangleright$  to confirm



**Turndown**

When the sensor is used to monitor a lower velocity range than the calibrated range, the complete response range of the sensor can be utilized by reducing the gain value.

Adjustable range: 5 to 30 m/s

Press  $\blacktriangleleft$  to traverse the digits  
Press  $\blacktriangleright$  to scroll the digit  
Press  $\blacktriangleright$  to confirm



**Units**

Select the preferred engineering units of flow velocity

Press  $\blacktriangleleft$  or  $\blacktriangleright$  to scroll  
Press  $\blacktriangleright$  to confirm

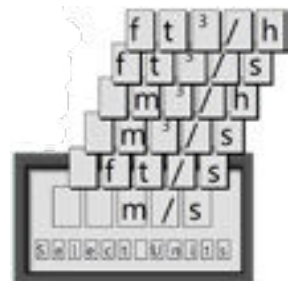

!

If a volumetric unit is selected it will be necessary to enter a cross-sectional multiplier relating to the flow path (see scale factor)

## Scale factor

Enter a cross-sectional multiplier when using volumetric units

The multiplier must be entered using the same units:

metres cubed/second: square metres

metres cubes/hour: square metres

feet cubed/second: square feet

feet cubed/hour: square feet



press to traverse the digits

press to scroll

press to confirm

## 4.2.1 Setup

The output signal parameters and operating functions can be programmed

press or to select

press to confirm



## Damping

The immediacy of response can be adjusted to suppress spurious changes of flow velocity.

Delay in seconds to reach 63% of scale

Range: 0 to 1000 seconds



press to traverse the digits

press to scroll

press to confirm

## Language



Choice of English, French, Spanish or German

press or to select

Press to confirm





**Contrast**

press  or  to SET the contrast  
 press  to confirm

**Decimal places**

When the sensor is measuring a rapidly fluctuating signal, the position of the decimal point can be moved.

press  to traverse the decimal point  
 press  to confirm

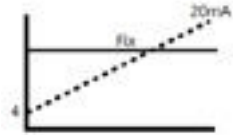

**Fix output**

If the process being monitored is shut down for maintenance, then to prevent an alarm condition being transmitted by the sensor the output signal can be fixed at any % value of the output signal range.



The fixed level selected is a calibrated value so this feature can also be used to test the integrity of the signal loop and any remote monitoring equipment by simulating an output signal of defined value.

Remote display systems can be calibrated and any alarm setpoint levels can be checked for function and accuracy.

press  to traverse the cursor  
 press  to increment the value of the digit above the cursor  
 press  to confirm



The signal will be released when the menu position is vacated.

**Master reset**

All data will be re-initialized equivalent to removing the power. All user settings will be retained.

press  to reset



The display will return to the signal display mode.

### 4.3 Output Signal Check

1. Using a test meter check that the value of the output signal agrees with the value of the display reading
2. After the completion of all maintenance, update the maintenance records



#### 4.3.1 Sensing Probe Function Test

1. Under normal circumstances, the calibration of the sensing probe will not change significantly.
2. Check the accuracy by comparing the display reading with a reference value flow velocity.

Alternatively:

The Vortex can be removed and returned to your Trolex service agent for checking and calibration across the full operating spectrum. Contact [service@trolex.com](mailto:service@trolex.com) for further information.

3. After completion of all maintenance, update the maintenance records.



#### 4.3.2 Sensing Probe Clean

1. Remove the sensor and clean the sensing head with a soft brush or cloth.

##### Checkpoint

Do not use sharp tools as this may cause damage to the ultrasound transducers and the transverse strut.

## 4.4 Disposal

Part of the ethos of Trolex is sustainable design. Vortex contains materials that can be recovered, recycled and reused. At the end of its useful life ensure that the

Vortex is recycled in accordance with local laws and bylaws for the geographic area where it is located. The end of its useful life is to be determined by the owner/operator of the equipment and not Trolex. Ensure that the Vortex is recycled by licenced waste contractors with the appropriate licences for handling metal, plastic and electronic waste in the geographic area where the Vortex is located.

### Checkpoint

Consult your local Trolex service agent or the Trolex Product Support Department if you require assistance with disposal:  
[service@trolex.com](mailto:service@trolex.com)

## 4.5 Maintenance Records

Implement a planned preventative maintenance process and keep good maintenance records.

Consult your local Trolex service agent or the Trolex Product Support Department: [service@trolex.com](mailto:service@trolex.com) for help in implementing a planned preventative maintenance process.

The 'Maintenance Log' gives an example of a typical maintenance record system.



## Disclaimers

The information provided in this document contains general descriptions and technical characteristics of the performance of the product. It is not intended as a substitute for and is not to be used for determining suitability or reliability of this product for specific user applications. It is the duty of any user or installer to perform the appropriate and complete risk analysis, evaluation and testing of the products with respect to the relevant specific application or use. Trolex shall not be responsible or liable for misuse of the information contained herein. If you have any suggestions for improvements or amendments, or find errors in this publication, please notify us at [marketing@trolex.com](mailto:marketing@trolex.com).

No part of this document may be reproduced in any form or by any means, electronic or mechanical, including photocopying, without express written permission of Trolex.

All pertinent state, regional, and local safety regulations must be observed when installing and using this product. For reasons of safety and to help ensure compliance with documented system data, only Trolex or its affiliates should perform repairs to components.

When devices are used for applications with technical safety requirements, the relevant instructions must be followed.

## Trademarks

© 2025 Trolex® Limited.

Trolex is a registered trademark of Trolex Limited. The use of all trademarks in this document is acknowledged.

## Document History

Issue 01	30 September 2014
A	10 April 2024
B	16 June 2025
C	22 April 2026

## Contact Details

Trolex Ltd, Newby Road, Hazel Grove, Stockport, Cheshire, SK7 5DY, UK  
+44 (0) 161 483 1435 [sales@trolex.com](mailto:sales@trolex.com)

**TROLEX**«